

S41

.E28

no.423

copy 5

Bulletin 423

March, 1936

U. S. GOVERNMENT
PRINTING OFFICE

APR 25 1973

THE PARSHALL
MEASURING FLUME

WATER RESOURCES
CSU LIBRARIES

By RALPH L. PARSHALL



COLORADO STATE COLLEGE
COLORADO EXPERIMENT STATION
FORT COLLINS

Prepared under the direction of W. W. McLaughlin, Chief, Division of
Irrigation, Bureau of Agricultural Engineering, United States Department
of Agriculture

Based on data gathered under cooperative agreement between the Bureau
of Agricultural Engineering, United States Department of Agriculture,
and the Colorado Experiment Station, Fort Collins, April, 1935.

L-818

Bulletin 423

March, 1936

E. H. LORGE
OF AUSTON

APR 25 1973

WATER RESOURCES
CSD LIBRARIES

THE PARSHALL MEASURING FLUME

By RALPH L. PARSHALL



COLORADO STATE COLLEGE
COLORADO EXPERIMENT STATION
FORT COLLINS

Prepared under the direction of W. W. McLaughlin, Chief, Division of Irrigation, Bureau of Agricultural Engineering, United States Department of Agriculture

Based on data gathered under cooperative agreement between the Bureau of Agricultural Engineering, United States Department of Agriculture, and the Colorado Experiment Station, Fort Collins, April, 1935.

7AT
E. W. Jones *W. A. ...*

Colorado State College
 FORT COLLINS, COLORADO

STATE BOARD OF AGRICULTURE

O. E. WEBB.....	Milliken	J. J. DOWNEY.....	Cortez
T. J. WARREN.....	Fort Collins	R. F. ROCKWELL.....	Paonia
MRS. MARY ISHAM.....	Brighton	JAMES P. McKELVEY.....	La Jara
J. W. GOSS.....	Pueblo	H. B. DYE, Pres.....	Manzanola

Ex-Officio { GOVERNOR EDWIN C. JOHNSON
 PRESIDENT CHARLES A. LORY

L. M. TAYLOR, Secretary-Treasurer

OFFICERS OF EXPERIMENT STATION

CHARLES A. LORY, M.S., LL.D., D.Sc.....	President
E. P. SANDSTEN, Ph.D.....	Director
L. D. CRAIN, M.M.E.....	Vice-Director
L. M. TAYLOR.....	Secretary
ANNA T. BAKER.....	Executive Clerk

EXPERIMENT STATION STAFF

Agronomy

Alvin Kezer, A.M., Chief Agronomist
 David W. Robertson, Ph.D., Associate
 Robert Gardner, M.S., Associate (Soils)
 *Warren H. Leonard, M.S., Associate
 Dwight Koonce, M.S., Assistant
 Dean C. Anderson, M.S., Assistant
 Otto Coleman, B.S., Assistant
 Robert Whitney, B.S., Assistant (Soils)

Animal Investigations

George E. Morton, M.S., in Charge
 H. B. Osland, M.S., Associate
 John O. Tolver, B.S., Assistant
 R. C. Tom, M.S., Assistant

Botany

L. W. Durrell, Ph.D., in Charge
 Anna M. Lute, A.B., B.Sc., Seed Analyst
 Bruce J. Thornton, M.S., Associate
 E. W. Bodine, M.S., Assistant
 Melvin S. Morris, M.S., Assistant
 A. O. Simonds, Ph.D., Assistant
 C. G. Barr, Ph.D., Assistant

Chemistry

J. W. Tobiska, M.A., in Charge
 Earl Douglass, M.S., Associate
 C. E. Vail, M.A., Associate

Entomology

George M. List, I. D., in Charge
 Charles R. Jones, Ph.D., Associate
 Miriam A. Palmer, I.A., M.S., Associate
 Leslie B. Daniels, M.S., Assistant

Home Economics

Inga M. K. Allison, M.S., in Charge
 Mark A. Barmore, Ph.D., Research Associate

*On leave.

Horticulture

A. M. Binkley, M.S., in Charge
 E. P. Sandsten, Ph.D., Horticulturist
 Carl Metzger, M.S., Associate
 George A. Beach, B.S., Assistant
 Herman Fauber, B.S., Assistant
 Ralph Manuel, B.S., Assistant
 Louis R. Bryant, Ph.D., Assistant

Irrigation Investigations

*R. L. Parshall, B.S., in Charge
 **Carl Rohwer, B.S., C.E., Associate
 W. E. Code, B.S., Associate
 R. E. Trimble, B.S., Meteorologist

Rural Economics and Sociology

L. A. Moorhouse, M.S., in Charge
 R. T. Burdick, M.S., Associate
 D. N. Donaldson, M.S., Associate
 G. S. Klemmedson, M. S., Associate
 H. B. Pingrey, M.S., Assistant

Pathology and Bacteriology

I. E. Newsom, D.V.M., in Charge
 H. W. Reuszer, Ph.D., Associate
 Bacteriologist
 A. H. Groth, B.S., D.V.M., Assistant
 C. W. Barber, D.V.M., Ph.D., Assistant

Engineering Division

Mechanical Engineering

L. D. Crain, M.M.E., Head of Division
 in Charge of Mechanical Engineering
 E. M. Mervine, M.E., Agricultural Engineer, U. S. D. A.

Civil Engineering

E. B. House, M.S., in Charge
 A. R. LeGault, B.S., Testing Engineer

Editorial Service

James R. Miller, Editor

*Senior Irrigation Engineer, Bureau of Agricultural Engineering, U. S. D. A.

**Associate Irrigation Engineer, Bureau of Agricultural Engineering, U. S. D. A.

541
.E28
no. 423
Copy 5

THE PARSHALL MEASURING FLUME¹

By RALPH L. PARSHALL

Water is the most valuable asset of Western agriculture. Large expenditures have been made in the development of irrigation works and canal systems to furnish water to farms. These, with the cost of preparing large areas of lands for irrigation and the establishment of legal rights to the use of water, represent a vast irrigation investment. The extensive outlays already made, and those which must be faced in the future, emphasize the great need for the conservation of irrigation supplies, and in this relation correct measurements of flow should be the basis of any plan of saving.

In many cases, the absence of suitable means for measuring flowing water is not an indication of indifference on the part of the users so much as a disclosure of their lack of knowledge of such devices. Measurement may be accomplished by various methods more or less suited to individual conditions, such as grade of canal or ditch, quantity of water, or interference with flow by sand and silt.

The right to use water for irrigation is decreed by the courts, which provide that definite amounts may be diverted from natural streams or water courses. Without measurement, the appropriator of water can not make a definite statement as to how much water he actually uses, and if a dispute should arise it would be difficult for him to furnish satisfactory proof of his established rights. In some of the Western States, because of the scarcity of water, it is of prime importance that its measurement be accurate. Where legal questions over water rights are involved, considerable advantage is to be gained by having definite records of measurements made by means of some practical device of recognized accuracy.

Sometimes, because of faulty measurements, the farmer's water supply is so restricted as to interfere seriously with the maturing of his crops. Were dependable measurements made, the increase in value of the crops would more than pay for the expense of installing and maintaining a good, reliable measuring device.

It would be expected that large irrigation systems, like any large manufacturing or commercial establishments with many ramifications, would measure all water deliveries with at least approximate exactness, yet many of them still estimate deliveries or use faulty methods of measurement. The principal asset of such irrigation enterprises is water, and their principal duty is the proper and economic distribution of the supply. Fairness to the water users and successful business management both demand that reliable measurements be made as a basis for all water transactions.

¹This bulletin is a revision of Colorado Experiment Station Bulletin 336, entitled "The Improved Venturi Flume," issued March 1928.



U18401 8611603

It is generally believed that the measurement of water is an intricate process, but accurate measurements can readily be made where the conditions are as specified for the proper setting or dimensions of the device. The water user himself, with little practice, should be able to measure the water delivered to him with a satisfactory degree of accuracy.

The measurement of water flowing in open channels is a matter of importance throughout the irrigated areas. The cost of the measuring structures is complained of in many instances, as well as the fact that the particular installation may not be well suited to the conditions under which it must operate. Accumulations of debris in many devices have rendered the measurements either questionable or obviously of no value, and such failures, in some cases, have discouraged the use of improved methods better suited to the conditions.

In the measurement of water in open channels, the weir has been most generally used for small-to-moderate flows. Laboratory tests indicate that it is the most accurate practical means for measuring water under favorable conditions; but if the pool or channel section immediately upstream from the weir crest accumulates sediment, the required vertical depth of water below the crest is correspondingly reduced, thus interfering with the accuracy of this method of measurement.

Where the grade of the channel is not sufficient to permit the use of standard weirs, orifices have been used with varying success. Experiments seem to indicate that the constants which apply to give the true discharges are affected by the shape of the orifice as well as by certain contraction distances which may or may not be correct, thus rendering the practical value of this device rather uncertain. However, its property of indicating the discharge with a relatively small loss in head is an advantage.

One of the devices most commonly used to measure large flows is the rating flume, which is a simple structure built in the channel where the floor is level, set to the grade line, and with its side walls either vertical or inclined. This flume is calibrated by current meter measurements, or by other means, where the rate of discharge varies with the depth of the stream, which is indicated by a staff gage set on the inside face of the flume. The ordinary rating flume is not altogether reliable. Often a deposit accumulates on the floor of the structure, thus cutting down the cross-section of the water prism, which, in turn, affects the velocity. Flow conditions downstream from the rating flume may change, causing the staff gage readings to be affected to such an extent that the indicated discharges will be considerably in error. Trailing grass, weeds, or willows in the water will affect the rate of flow, which causes error in the discharge readings. On the other hand, a smaller loss of head will suffice for measurements by means of the rating flume

than for any other practical device, and for this reason it is very commonly used.

Early in 1915, tests were conducted at the Fort Collins hydraulic laboratory of the Colorado Experiment Station on a water-measuring device having a converging inlet, straight-throat section, and a diverging outlet, with a level floor throughout. These tests were made to determine the most practical angles of convergence and divergence with relation to the contracted section, as well as the practical length of the structure. The walls of some of the tested structures were vertical; in others they inclined outward from the axis. After certain conclusions bearing upon the most practical dimensions to be used had been reached, a series of calibrations was made on flumes of various widths and of both these types. The first tests were made by V. M. Cone and were reported by him in the *Journal of Agricultural Research*, Vol. IX, No. 4, p. 115, April 1917. Because of the many apparent practical advantages of the device, more extensive investigations were made at the hydraulic laboratory, Cornell University, Ithaca, N. Y., where large flows were available.²

The water-measuring device herein described, called the Parshall measuring flume,³ is believed to possess the characteristics which will make it meet general field conditions more successfully than its predecessor, the Venturi flume, as well as obviate many of the objections to the weir, orifice, rating flume, or other measuring devices now in general use. This measuring flume is intended primarily to meet general field conditions where extreme accuracy in the measurement is not required.

The accuracy of discharge measurements with the Parshall measuring flume is indicated by the experiments to be, under normal operating conditions, within 2 to 5 percent.

Experience in the field and in the laboratory with the old type of Venturi flume indicates that in order to operate this device successfully it is necessary that the heads be observed simultaneously at each side of the structure at the H_a and H_b gage points, and that the mean values of these readings be used to determine the rate of flow. Tests and field observations on the new device show that, for free flow, the discharge may be determined by a single gage reading. For the determination of submerged flow, two gage readings are necessary, two of the four gages formerly required being eliminated. This report presents the discharge data in tabular form, which is believed to be more convenient than that given in former reports on the Venturi flume.

²These data, together with additional observations, were reported in Bulletin 265 of the Colorado Experiment Station, entitled "The Venturi Flume." 1921.

³This measuring device has been named the Parshall measuring flume at the recommendation of the Irrigation Committee of the American Society of Civil Engineers, with the approval of the Bureau of Agricultural Engineering, United States Department of Agriculture, and the Colorado Experiment Station.

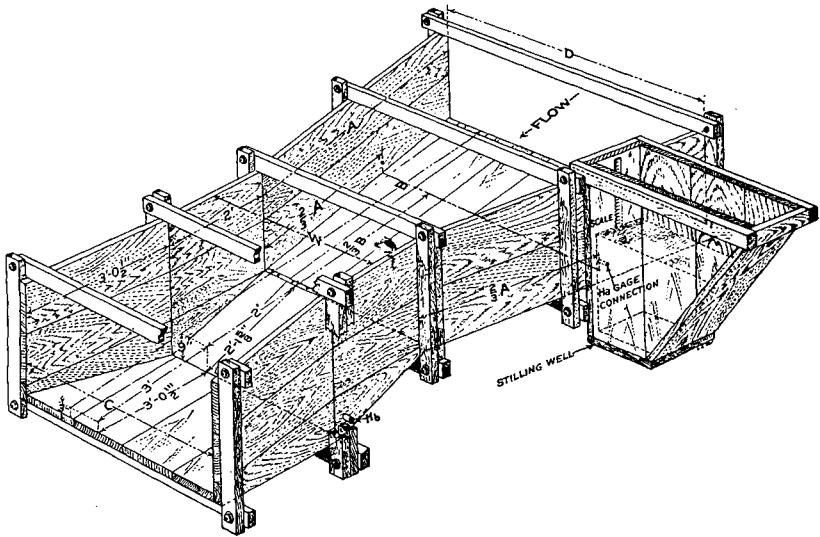

Figure 1.—The Parshall measuring flume, with stilling well provided with inside staff gage capable of more accurate head readings.

The Parshall measuring flume differs in design from the old type in the reduction of the convergence angle from $18^{\circ} 26'$ to $11^{\circ} 19'$ for its upstream or inlet section, a lengthening of the throat section from 1 foot to 2 feet, reduction of the divergence angle of the lower or outlet section from $18^{\circ} 26'$ to $9^{\circ} 28'$, and the placing of a depression in the floor at the throat section. The length of the side wall of the converging section (in feet) is also changed in accordance with the arbitrary rule

$$A = \frac{W}{2} + 4 \quad ^4$$

The length of the converging side of the structure is discussed more fully in another section of this bulletin. The length of the diverging section has been taken as 3 feet for all widths at the throat section from 1 to 8 feet inclusive.⁴ In the old flume the floor was level throughout, whereas in the improved type the floor in the throat section slopes downward at a rate of 9 inches vertically to 24 inches horizontally. At the point where the diverging section begins, the floor slopes upward at a rate of 6 inches vertically to 36 inches horizontally. The floor at the lower end of the flume is 3 inches below the floor level of the upper or converging section. The 3-, 6-, and 9-inch flumes, discussed elsewhere, are of special design.

HYDRAULIC LABORATORIES

Two laboratories were used in developing this flume. At one, accurate and precise work is possible; the other is a field laboratory

⁴The general dimension of the flume as shown in figure 1 refers to the tabular dimensions given in table I.

of sufficient capacity to permit the study of flow through structures of large size where the accuracy in measurement of flow is well within practical limits. The Fort Collins laboratory⁵ has a capacity of about 16 second-feet, where the discharge is measured volumetrically. Outside, at an elevation above the laboratory floor, is the supply reservoir which has a capacity of 3/4 acre-foot. The water is led from this reservoir by means of a channel into the laboratory, where the experimental structures are tested. There it is possible to maintain a specific depth or discharge long enough to determine quite closely the condition of flow. It has been found possible to make calibrations come within about 0.005 second-foot of the discharges determined volumetrically.

TABLE I.—STANDARD DIMENSIONS AND CAPACITIES OF THE PARSHALL MEASURING FLUME

(Letters refer to figure 1)

Crest Length W	Dimensions in feet and inches						Free-flow capacity			
	A	3/4A	B	3/4B	C	D	Maximum Head H ₁	Disch.	Minimum Head H ₂	Disch.
Ft.							Ft.	Sec.-ft.	Ft.	Sec.-ft.
1	4' 6"	3' 0"	4' 4 7/8"	2' 11 1/4"	2	2' 9 1/4"	2.50	16.1	0.20	0.35
2	5' 10"	3' 4"	4' 10 7/8"	3' 3 1/4"	3	3' 11 1/2"	2.50	33.1	0.20	0.66
3	5' 6"	3' 8"	5' 4 3/8"	3' 7 1/8"	4	5' 1 7/8"	2.50	50.4	0.20	0.97
4	6' 0"	4' 0"	5' 10 5/8"	3' 11 1/8"	5	6' 4 1/4"	2.50	67.9	0.20	1.26
5	6' 6"	4' 4"	6' 4 1/2"	4' 3"	6	7' 6 5/8"	2.50	85.6	0.25	2.22
6	7' 0"	4' 8"	6' 10 3/8"	4' 6 7/8"	7	8' 9"	2.50	103.5	0.25	2.63
7	7' 6"	5' 0"	7' 4 1/2"	4' 10 7/8"	8	9' 11 3/8"	2.50	121.4	0.30	4.08
8	8' 0"	5' 4"	7' 10 1/8"	5' 2 3/4"	9	11' 1 3/4"	2.50	139.5	0.30	4.62

For flumes of larger size see Experiment Station Bulletin 386, "Parshall Flumes of Large Size."

⁵For a more complete description, see Eng. News, Vol. 70, p. 662, October, 1913.

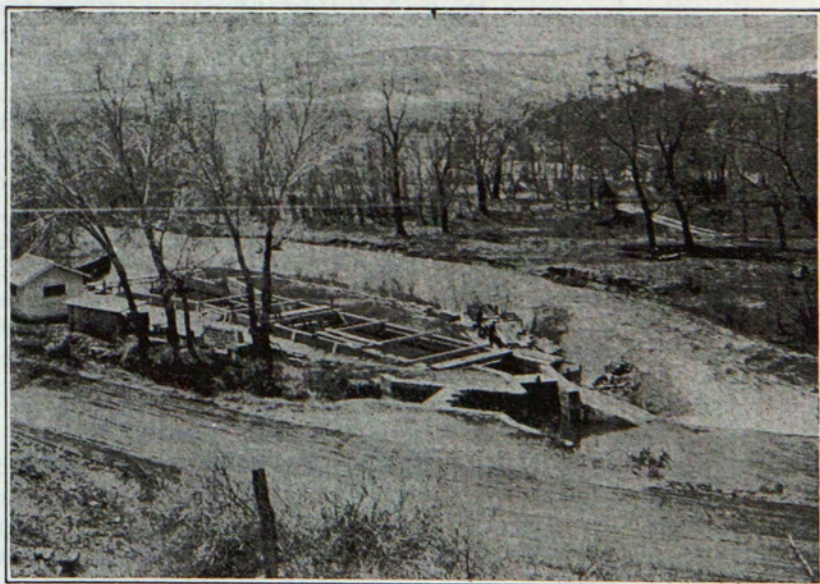

Figure 2.—Irrigation hydraulic laboratory at Bellvue, Colo.

The volumetric tanks are of reinforced concrete, their capacity being approximately that of the supply reservoir. The amount of water added to these tanks or basins for any particular test is determined by hookgauge readings to a limit of 0.001 foot. An electrically-driven centrifugal pump returns the water to the supply reservoir for use again. The calibrations of the smaller flumes were made at this laboratory, where the discharges were measured to thousandths of second-feet, and the depths or heads affecting the discharge through the flumes were determined by hookgauge readings. These experimental structures were built of wood or sheet metal, accurate in dimension and of sufficient depth to cover a range of discharge such as would be found in actual field practice.

The field laboratory at Bellvue (fig. 2) is 8 miles west of Fort Collins at the headworks of the Jackson Ditch, on the Cache la Poudre River. It consists of a reinforced concrete channel 14 feet wide and $6\frac{1}{2}$ feet deep, with a present over-all length of about 150 feet. At the lower end of this channel is a weir box 25 feet wide and 10 feet deep, having in the end wall a 15-foot standard rectangular weir. At this laboratory, in 1923, when the calibrations were made on the larger sizes of the Parshall measuring flume, the concrete weir box was of the same width as the channel and had a depth of $7\frac{1}{2}$ feet for a distance of 24 feet. In the end wall of this weir box was a 10-foot standard rectangular weir, patterned after the 10-foot weir calibrated by J. B. Francis in the early fifties at Lowell, Mass. Because these weirs were of similar dimensions, the discharge curve for the weir used was based upon the results of Francis' experiments. The larger Parshall measuring flumes were built in this concrete channel at a point upstream from the weir box. The water was admitted to this channel at its upper end, thence flowed through the experimental structures and finally was carefully measured over the standard weir. Hookgages were mounted on the model structures at such points as permitted careful measurement of the upper head, H_a , and the throat head, H_b . The head on the standard weir was determined by means of two hookgauge readings on opposite sides of the weir box (fig. 30). All hookgauge readings were observed to a limit of 0.001 foot. Downstream from the experimental flumes an adjustable baffle was provided which permitted the regulation of the degree of submergence. At this laboratory, calibrations were made for flows ranging from 5 to 90 second-feet.

ACTION OF THE PARSHALL MEASURING FLUME

The fundamental idea dictating the design of the flume is based upon the effect of the increasing velocity in the converging section, resulting from the constantly decreasing cross-section of the water prism. As the flowing stream reaches the crest, which is the junction of the upper level floor and throat floor, it has virtually attained its maximum velocity. For the free-flow condition, the stream is carried

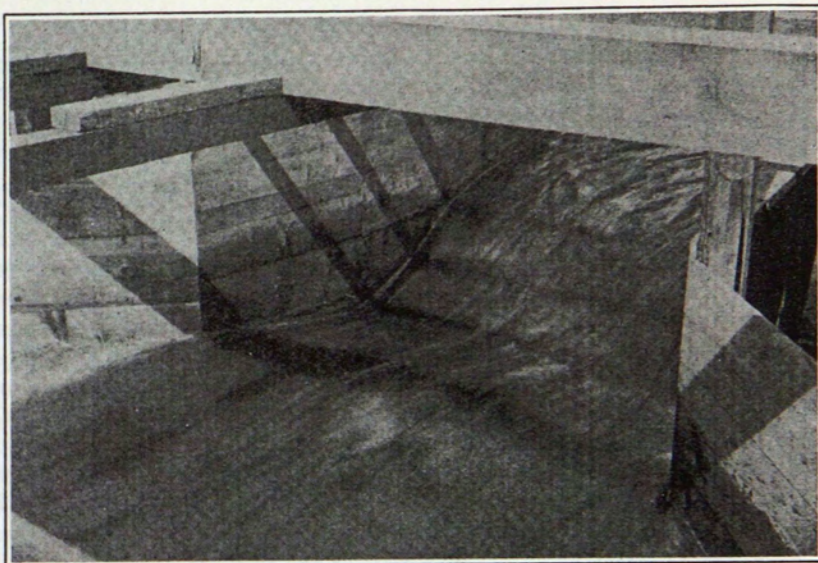

Figure 3.—Experimental 6-foot Parshall measuring flume. Free-flow discharge. Bellvue hydraulic laboratory.

down the inclined floor of the throat, and with the momentum thus acquired is carried upward over the inclined floor of the diverging section to the exit end of the structure. Because there is no obstruction to the flow as just described, this condition is called free flow, as shown in figures 3, 12, 21, 26, and 27. When the resistance to the flowing water in the channel downstream from the flume is great enough, the momentum through the throat section is not sufficient to permit clearing smoothly in the diverging section. By thus restricting the flow, the water surface is raised in the exit end of the flume. In this transition of flow, the phenomenon occurs known as the "hydraulic jump". Because of the downward inclined floor of the throat section, this jump is produced at some distance downstream from the crest, and is, in effect, the means of warding off or holding back the resisting water in the diverging section. In the formation of the hydraulic jump, a portion of the velocity head in the stream passing the crest is converted into static head, which causes the stream to flow at a slower velocity but with greater depth beyond the point where the jump is formed. As the resistance to the flow in the diverging section is further increased, the jump is reduced in its effectiveness and at the same time crowded back into the throat section. As the jump moves upstream into the throat section, a condition of downstream depth is reached where the momentum or push of the water over the crest is reduced by the resistance to the point of decreasing the discharge. This point is called the limiting depth or critical degree of sub-

mergence, and is important because it defines the limit of free-flow discharge. The amount of water flowing will be undiminished until the water surface at the lower or downstream edge of the throat has been raised to such a point that the depth here, or H_b , is approximately 0.7⁶ of that in the converging section at the gage point H_a , where both these depths are referred to the crest elevation as the datum. When the resistance to the flow downstream from the structure is further increased, because of lack of grade or checking of the flow by means of flashboards, or otherwise raising the water surface beyond this limiting depth, a reduction in the discharge results. This condition is called submerged flow.

In this discussion the degree of submergence is the ratio of the throat gage, H_b , to the upper gage, H_a , expressed as a decimal fraction.

In the plan and elevation views of the Parshall measuring flume (fig. 13), the lower water surface, Q, in the downstream section shows the condition of free flow, while the upper surface, P, indicates the approximate elevation of the free-flow discharge limit. The elevation of this surface at any point between is within the free-flow zone, and the discharge for this range is a function of the flume's width or size and of the upper head, H_a , which is measured at the two-thirds point along the converging side of the structure.

CHARACTERISTICS OF THE FLUME.—The practical use of the Parshall measuring flume has demonstrated that it possesses many desirable characteristics and is not subject to many of the disadvantages of other devices. It may be operated either as a free-flow, single-head device, or under submerged flow conditions where two heads are involved. Because of the contracted section at the throat, the velocity of water flowing through the structure is relatively greater than the natural flow of the stream, and for this reason any sand or silt in suspension or rolled along the bottom of the channel is carried through, leaving the flume free of deposit. Velocity of approach, which often becomes a serious factor in the operation of weirs, has little or no effect upon the rate of discharge of the flume. (See discussion page 44-46.) It is accurate enough for all irrigation purposes, and since it remains clear of sediment the reliability of its measurement is believed to be greater than that of other methods. Usually, conditions found in the field will permit it to operate with a free-flow discharge, which is a function only of a single depth, as with a weir. The loss of head for the free-flow limit is found to be about 25 percent of that for the standard overpour weir. There is no easy way to alter the dimensions or cause a change in the flume, modify the channel above or below the structure, or otherwise interfere with the original conditions for the purpose of increasing the discharge to effect a wilfully unfair measurement.

⁶This limit is applicable for flumes of 1-foot widths or greater. For flume of small size see discussion page 29.

The design and performance of this device have shown that it is capable of withstanding a high degree of submergence before the rate of discharge is reduced. Because of this fact it will operate successfully where the overpour weir fails because of the flat grade of the channel. A wide range of capacity of measurement has been provided in its calibration, and it is, therefore, adapted to use on the small farm lateral as well as on channels of large capacity.⁷ The structure itself may be built of either wood or concrete, or, for the smaller flumes, of sheet metal. The fact that the design specifies certain angles does not greatly increase the work of building, since all surfaces are plane; hence the material may be readily cut to fit properly. The practical operation of the flume is simple, and any observer can make the necessary readings and apply them to the table and diagrams to determine the discharge. Where the flow through the flume is submerged, and two heads or depths are observed, a graphic recording instrument may be used which indicates on a chart the value of these two heads (see fig. 28). These recorded data, referred to the size of the flume, are sufficient to determine the total flow over any period of time.

CONSTRUCTION OF EXPERIMENTAL FLUMES AND METHOD OF OBSERVATION

The experimental flumes at both the Fort Collins and Bellvue laboratories were of ordinary lumber. The sills and posts were 2- by 4-inch pieces, while the floor and walls were made of 1-inch boards surfaced on both sides. In the building of these structures particular care was taken to have all dimensions exact. When the side walls and floor became wet they swelled, and due allowance was made in having the throat width or size of flume slightly greater than the nominal length in order that, when the structure was completely soaked, the swelling would bring the dimension close to the true value. Dimensions of the structure were checked occasionally to see whether or not they remained within practical limits.

The stilling wells were metal cans, about 10 inches in diameter and from 3 to 6 feet deep. The deeper cans were used at the Bellvue laboratory as a matter of convenience. In the mounting of hookgages, care was taken to have them securely fixed. At the Bellvue laboratory, a 2- by 6-inch plank was set vertically and rigidly fixed to insure against error in depth measurements. The metal stilling well was placed against the face of the plank, resting firmly upon a solid base. A $\frac{3}{4}$ -inch pipe connection was provided at the bottom of the well, and from this was led a piece of common garden hose of the same diameter, connecting to the wall of the flume by a similar pipe connection at the desired point. In the concrete channel downstream from the experi-

⁷Colorado Experiment Station Bulletin 336, "Parshall Flumes of Large Size," 1932, discusses flumes of larger size, maximum throat width of 50 feet, and having a capacity of 3,000 second-feet.

mental flume was a 22- by 22-inch metal gate, placed in a framework consisting of a set of flashboards. This gate and the flashboards made it possible to secure various degrees of submergence and to regulate the flow through the test structure. Baffles were placed upstream from the experimental flume as well as downstream below the submergence bulkhead.

Each morning before operations were begun, all hookgage constants were determined by means of an engineer's level and rod. The mean elevation of the crest of the test flume was accurately determined by several observations at different points. A light wooden rod with sliding target was placed at a point of mean elevation and the target set exactly at the line of sight of the instrument. This rod was then placed upon the various hooks of the gages, and the gages were adjusted so that the target again agreed with the line of sight of the leveling instrument. The hookgage readings then gave the constant of correction for each gage. This same method was employed to determine the hookgage constants for the standard rectangular weirs.

Water was admitted to the concrete channel by means of the main regulating gate, and after the flow had assumed a constant condition observations were taken as follows: An observer started by reading the upper head, or H_u , on the flume, calling this observation to a note-keeper who recorded it on a special form, and then read in proper order all other hookgages, calling the readings as they were observed. For the most part, five hookgages were observed, three on the experimental flume and two on the standard weir. A complete round of readings usually required about $1\frac{1}{2}$ minutes, and where the variations in the water surface were small, five complete sets were assumed to be sufficient to give the correct mean; otherwise, more observations were taken.

In the old type of Venturi flume it was found that the downstream flow conditions were such as to swing the current from one side to the other, apparently without cause. This swinging was found to affect the reading of head in the converging section. To determine whether or not heads observed on either side of the converging section of the Parshall measuring flume were the same, approximately 200 observations were made in 1923 by having two hookgage connections, one on each side at the proper point. These observations show that the difference in the two readings was very small, and it can, therefore, be safely assumed that the upper head, H_u , may be observed on either side with equal accuracy.

At the Bellvue laboratory, the loss of head through the flume was determined by staff gages read direct, the zero of the gages being set at the elevation of the floor of the converging section. These gages were so situated that the elevation of the water above and below the flume could be determined quite accurately. At the Fort Collins

laboratory, where calibrations were made on the smaller-sized flumes of small discharge, the loss of head was determined by means of hookgage readings.

FREE-FLOW FORMULA

The data upon which the free-flow formula is based consist of the discharges in second-feet and the corresponding heads, H_a , for 159 tests, where the degree of submergence is less than 70 percent, these tests being divided according to size of flume as follows: 1-foot flume, 27 tests; 2-foot flume, 28 tests; 3-foot flume, 34 tests; 4-foot flume, 21 tests; 6-foot flume, 20 tests; and the 8-foot flume, 29 tests. The data obtained from the tests, when plotted to a logarithmic scale for the various discharges and corresponding heads, showed very nearly a straight-line variation for the various sizes of flumes tested. Upon adjusting a straight line to these individual sets of plottings, it was observed that the discharge intercepts for the upper head, H_a , at one foot are very closely proportional to four times the width of the flume in feet. The slope of the lines for the various sizes of flume is not the same, thus showing that the values of the exponent of the upper head, H_a , are not identical and therefore vary with the width or size of flume. By careful inspection of the plotted data, values of the intercept and slope have been determined for each size of flume, as given in table II.

TABLE II.—VALUES OF INTERCEPT J AND SLOPE n, LOG PLOT FOR LAW OF FREE-FLOW DISCHARGE THROUGH DIFFERENT-SIZED PARSHALL MEASURING FLUMES

Size of flume W	Coefficient J Intercept log plot	Computed value 4W	Differ- ence	Exponent n of H_a Scaled value log plot	Computed value of $1.522W^{0.028}$	Differ- ence
Feet						
1	3.98	4.00	+0.02	1.527	1.522	-0.005
2	8.00	8.00	.00	1.552	1.550	-.002
3	11.96	12.00	+ .04	1.565	1.566	+ .001
4	16.02	16.00	-.02	1.574	1.578	+ .004
6	24.05	24.00	-.05	1.592	1.595	+ .003
8	32.00	32.00	.00	1.608	1.606	-.002

The fundamental law for the free-flow discharge through the Parshall measuring flume is:

$$Q = J H_a^n$$

- where Q = Quantity in second-feet
- J = Coefficient which is a function of the size of the flume
- H_a = The upper head in feet observed at a point distant upstream from the crest two-thirds the length of the converging section
- n = Exponent of the head, H_a

By inspection of the data in table II, it is evident that, as an approximation, $J = 4W$, where W is the size of flume or width of throat, in feet. The relation of the slope n , and width of flume W has been

established as $n = 1.522W^{0.026}$. Hence, the complete formula may be stated as

$$Q = 4WH_a^{1.522W^{0.026}}$$

The form of expression employing the double exponent of H_a may at first appear to be complicated and unusual. However, when the simple operation is performed to reduce to the proper value of the exponent for the particular width of flume, the form of the expression for the discharge offers no more difficulty in its solution than the simple discharge formula for a standard weir or submerged orifice. This equation, being in the product form, is readily solved by means of logarithms.

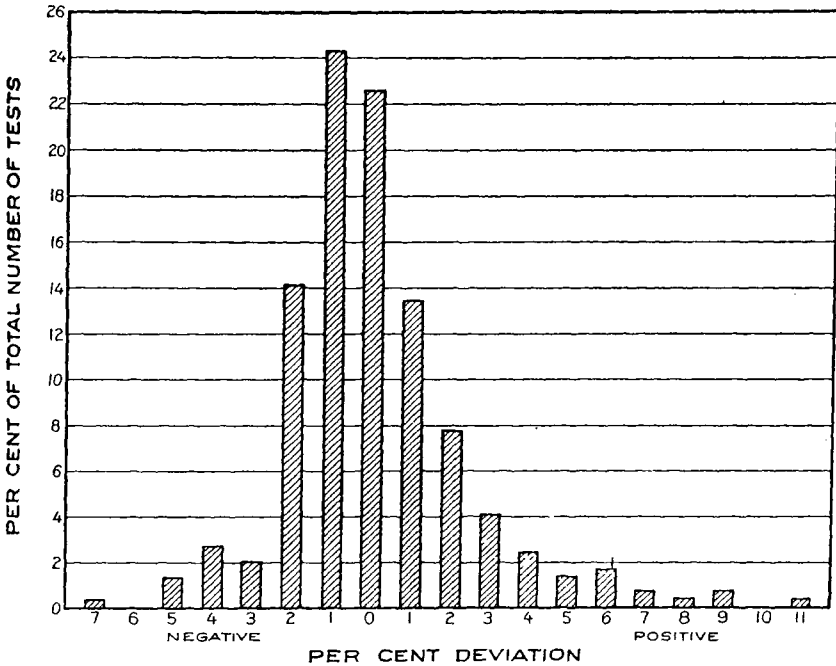

Figure 4.—Comparison in percentage of computed with observed free-flow discharge through experimental flumes.

Figure 4 shows graphically the agreement of the computed discharge, as determined by the free-flow formula, with the observed discharge as the base. This comparison includes, in addition to the 159 original tests made in 1923, the 139 check tests made in 1926. The data upon which this diagram is based were developed by expressing the deviation between the observed and computed discharge as a percentage. Where the computed was greater than the observed discharge, the percentage was positive, and where the computed was less than the observed discharge the percentage was negative. A tabulation was then made of these values, in which zero deviation included

all values between -0.4 and $+0.5$ inclusive; 1 percent positive including all values between $+0.6$ and $+1.5$ inclusive, and 1 percent negative all values between -1.4 and -0.5 inclusive. On this same basis the range of positive and negative values was extended to account for all the free-flow observations on the 1-, 2-, 3-, 4-, 6-, and 8-foot flumes.⁸

The height, or ordinate of the bars in the error diagram, figure 4, shows the percentage of total of 298 tests, limited in head, H_a , from 0.2 foot to 2.5 feet and with the limiting degree of submergence of 69.9 percent. For the distribution of the original 159 tests, it was found that approximately 97 percent of the total number fell within the limit of ± 3 percent of the computed value of the discharge; while for the total 298 tests, 89 percent were within this limit.

When the series of tests, consisting of 139 observations on the 1-, 2-, 4-, 6-, and 8-foot flumes, made at Bellvue laboratory in 1926, was included with the original tests, a wider variation of the deviation between the observed and computed discharges was found to exist. In the original series of 1923 there were about twice as many tests made

⁸Of the total of 308 free-flow tests, two were excluded because of gross error. (6512, 3-foot flume, and 7043, 8-foot flume). Six special tests (7625-26, 7739-40, 2-foot flume, and 6525-26, 3-foot flume) were excluded. Tests 6476-77 were omitted because the value of H_a exceeded 2.5 feet. Summary as follows:

Test	W	H_a	H_b	Ratio H_b/H_a	Observed Q	Computed Q	Difference	Deviation
	Feet	Feet	Feet		Sec.-ft.	Sec.-ft.	Sec.-ft.	Per cent
6476	1	2.722	1.795	0.659	18.13	18.36	-0.23	1.3
6477	1	2.641	1.726	.653	17.34	17.54	-.20	1.2

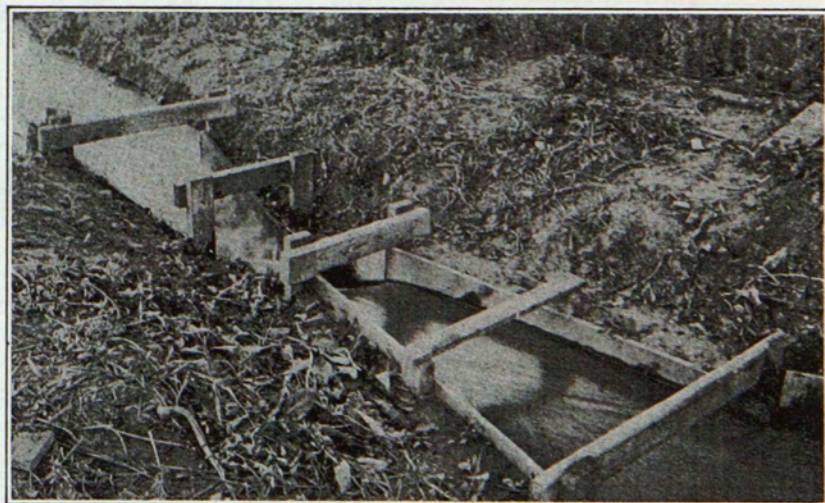

Figure 5.—One-foot Parshall measuring flume on Jones Lateral near Longmont, Colo. Free-flow discharge of about $2\frac{1}{4}$ second-feet.

at the Fort Collins hydraulic laboratory, volumetric measurements, on the 1-, 2-, and 3-foot flumes, as were taken at the Bellvue laboratory. The 1926 tests were all made at the Bellvue laboratory where rectangular weirs, 18 inches, 48 inches, and 15 feet in dimensions, were used to determine the observed discharge, (fig. 30).

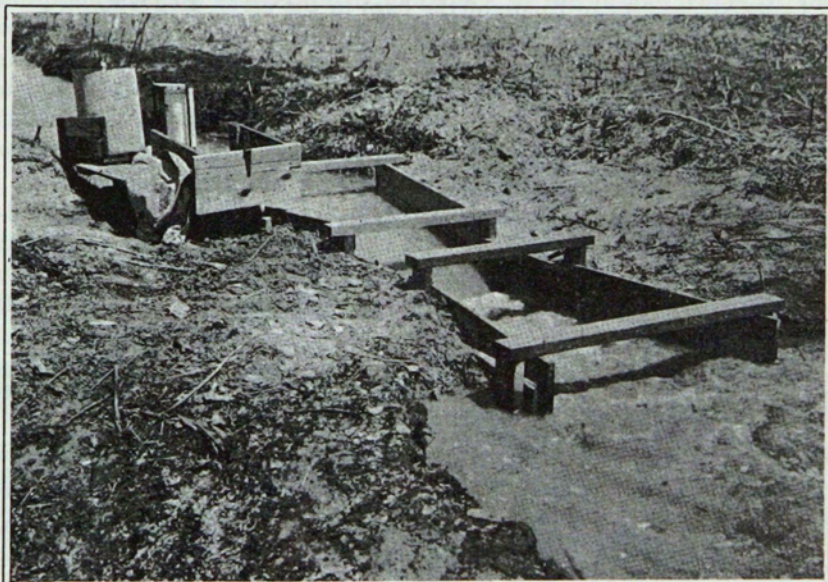

Figure 6.—Two-foot Parshall measuring flume discharging 5.7 second-feet; submergence 50 percent; loss of head about 0.4 foot, Mitchell farm lateral, near Las Animas, Colo.

TABLE III.—FREE-FLOW DISCHARGE FOR PARSHALL MEASURING FLUME

Computed from the formula $Q=4WH_{a1.522}w^{0.026}$

Upper Head H_a		Discharge per second for flumes of various throat widths							
		1	2	3	4	5	6	7	8
Feet	Inches	Foot	Feet	Feet	Feet	Feet	Feet	Feet	Feet
		Cu. ft.	Cu. ft.	Cu. ft.	Cu. ft.	Cu. ft.	Cu. ft.	Cu. ft.	Cu. ft.
.20	2 $\frac{3}{8}$.35	.66	.97	1.26				
.21	2 $\frac{1}{2}$.37	.71	1.04	1.36				
.22	2 $\frac{3}{8}$.40	.77	1.12	1.47				
.23	2 $\frac{3}{4}$.43	.82	1.20	1.58				
.24	2 $\frac{7}{8}$.46	.88	1.28	1.69				
.25	3	.49	.93	1.37	1.80	2.22	2.63		
.26	3 $\frac{1}{8}$.51	.99	1.46	1.91	2.36	2.80		
.27	3 $\frac{1}{4}$.54	1.05	1.55	2.03	2.50	2.97		
.28	3 $\frac{3}{8}$.58	1.11	1.64	2.15	2.65	3.15		
.29	3 $\frac{1}{2}$.61	1.18	1.73	2.27	2.80	3.33		
.30	3 $\frac{5}{8}$.64	1.24	1.82	2.39	2.96	3.52	4.08	4.62
.31	3 $\frac{3}{4}$.68	1.30	1.92	2.52	3.12	3.71	4.30	4.88
.32	3 $\frac{7}{8}$.71	1.37	2.02	2.65	3.28	3.90	4.52	5.13
.33	3 $\frac{1}{2}$.74	1.44	2.12	2.78	3.44	4.10	4.75	5.39
.34	4 $\frac{1}{8}$.77	1.50	2.22	2.92	3.61	4.30	4.98	5.66
.35	4 $\frac{1}{4}$.80	1.57	2.32	3.06	3.78	4.50	5.22	5.93
.36	4 $\frac{3}{8}$.84	1.64	2.42	3.20	3.95	4.71	5.46	6.20
.37	4 $\frac{1}{2}$.88	1.72	2.53	3.34	4.13	4.92	5.70	6.48
.38	4 $\frac{3}{4}$.92	1.79	2.64	3.48	4.31	5.13	5.95	6.76
.39	4 $\frac{7}{8}$.95	1.86	2.75	3.62	4.49	5.35	6.20	7.05

Upper Head H _a		Discharge per second for flumes of various throat widths							
		1	2	3	4	5	6	7	8
		Foot	Foot	Foot	Foot	Foot	Foot	Foot	Foot
Feet	Inches	Cu. ft.	Cu. ft.	Cu. ft.	Cu. ft.	Cu. ft.	Cu. ft.	Cu. ft.	Cu. ft.
.40	4 $\frac{1}{8}$.99	1.93	2.86	3.77	4.68	5.57	6.46	7.34
.41	4 $\frac{1}{8}$	1.03	2.01	2.97	3.92	4.86	5.80	6.72	7.64
.42	5 $\frac{1}{8}$	1.07	2.09	3.08	4.07	5.05	6.02	6.98	7.94
.43	5 $\frac{1}{8}$	1.11	2.16	3.20	4.22	5.24	6.25	7.25	8.24
.44	5 $\frac{1}{4}$	1.15	2.24	3.32	4.38	5.43	6.48	7.52	8.55
.45	5 $\frac{3}{8}$	1.19	2.32	3.44	4.54	5.63	6.72	7.80	8.87
.46	5 $\frac{3}{8}$	1.23	2.40	3.56	4.70	5.83	6.96	8.08	9.19
.47	5 $\frac{3}{8}$	1.27	2.48	3.68	4.86	6.03	7.20	8.36	9.51
.48	5 $\frac{3}{8}$	1.31	2.57	3.80	5.03	6.24	7.44	8.65	9.84
.49	5 $\frac{7}{8}$	1.35	2.65	3.92	5.20	6.45	7.69	8.94	10.17
.50	6	1.39	2.73	4.05	5.36	6.66	7.94	9.23	10.51
.51	6 $\frac{1}{8}$	1.44	2.82	4.18	5.53	6.87	8.20	9.53	10.85
.52	6 $\frac{1}{4}$	1.48	2.90	4.31	5.70	7.09	8.46	9.83	11.19
.53	6 $\frac{3}{8}$	1.52	2.99	4.44	5.88	7.30	8.72	10.14	11.54
.54	6 $\frac{1}{2}$	1.57	3.08	4.57	6.05	7.52	8.98	10.45	11.89
.55	6 $\frac{5}{8}$	1.62	3.17	4.70	6.23	7.74	9.25	10.76	12.24
.56	6 $\frac{5}{8}$	1.66	3.26	4.84	6.41	7.97	9.52	11.07	12.60
.57	6 $\frac{7}{8}$	1.70	3.35	4.98	6.59	8.20	9.79	11.39	12.96
.58	6 $\frac{7}{8}$	1.75	3.44	5.11	6.77	8.43	10.07	11.71	13.33
.59	7 $\frac{1}{8}$	1.80	3.53	5.25	6.96	8.66	10.35	12.03	13.70
.60	7 $\frac{1}{8}$	1.84	3.62	5.39	7.15	8.89	10.63	12.36	14.08
.61	7 $\frac{1}{8}$	1.88	3.72	5.53	7.34	9.13	10.92	12.69	14.46
.62	7 $\frac{1}{8}$	1.93	3.81	5.68	7.53	9.37	11.20	13.02	14.84
.63	7 $\frac{1}{8}$	1.98	3.91	5.82	7.72	9.61	11.49	13.36	15.23
.64	7 $\frac{1}{4}$	2.03	4.01	5.97	7.91	9.85	11.78	13.70	15.62
.65	7 $\frac{3}{8}$	2.08	4.11	6.12	8.11	10.10	12.08	14.05	16.01
.66	7 $\frac{3}{8}$	2.13	4.20	6.26	8.31	10.34	12.38	14.40	16.41
.67	8 $\frac{1}{8}$	2.18	4.30	6.41	8.51	10.59	12.68	14.75	16.81
.68	8 $\frac{1}{8}$	2.23	4.40	6.56	8.71	10.85	12.98	15.10	17.22
.69	8 $\frac{1}{4}$	2.28	4.50	6.71	8.91	11.10	13.28	15.46	17.63
.70	8 $\frac{3}{8}$	2.33	4.60	6.86	9.11	11.36	13.59	15.82	18.04
.71	8 $\frac{3}{8}$	2.38	4.70	7.02	9.32	11.62	13.90	16.18	18.45
.72	8 $\frac{3}{8}$	2.43	4.81	7.17	9.53	11.88	14.22	16.55	18.87
.73	8 $\frac{3}{8}$	2.48	4.91	7.33	9.74	12.14	14.53	16.92	19.29
.74	8 $\frac{7}{8}$	2.53	5.02	7.49	9.95	12.40	14.85	17.29	19.71
.75	9	2.58	5.12	7.65	10.16	12.67	15.17	17.66	20.14
.76	9 $\frac{1}{8}$	2.63	5.23	7.81	10.38	12.94	15.49	18.04	20.57
.77	9 $\frac{1}{4}$	2.68	5.34	7.97	10.60	13.21	15.82	18.42	21.01
.78	9 $\frac{3}{8}$	2.74	5.44	8.13	10.81	13.48	16.15	18.81	21.46
.79	9 $\frac{1}{2}$	2.80	5.55	8.30	11.03	13.76	16.48	19.20	21.91
.80	9 $\frac{5}{8}$	2.85	5.66	8.46	11.25	14.04	16.81	19.59	22.36
.81	9 $\frac{5}{8}$	2.90	5.77	8.63	11.48	14.32	17.15	19.99	22.81
.82	9 $\frac{7}{8}$	2.96	5.88	8.79	11.70	14.60	17.49	20.39	23.26
.83	9 $\frac{7}{8}$	3.02	6.00	8.96	11.92	14.88	17.83	20.79	23.72
.84	10 $\frac{1}{8}$	3.07	6.11	9.13	12.15	15.17	18.17	21.18	24.18
.85	10 $\frac{1}{8}$	3.12	6.22	9.30	12.38	15.46	18.52	21.58	24.64
.86	10 $\frac{1}{4}$	3.18	6.33	9.48	12.61	15.75	18.87	21.99	25.11
.87	10 $\frac{1}{4}$	3.24	6.44	9.65	12.84	16.04	19.22	22.40	25.58
.88	10 $\frac{1}{8}$	3.29	6.56	9.82	13.07	16.33	19.57	22.82	26.06
.89	10 $\frac{1}{8}$	3.35	6.68	10.00	13.31	16.62	19.93	23.24	26.54
.90	10 $\frac{3}{8}$	3.41	6.80	10.17	13.55	16.92	20.29	23.66	27.02
.91	10 $\frac{3}{8}$	3.46	6.92	10.35	13.79	17.22	20.65	24.08	27.50
.92	11 $\frac{1}{8}$	3.52	7.03	10.53	14.03	17.52	21.01	24.50	27.99
.93	11 $\frac{1}{8}$	3.58	7.15	10.71	14.27	17.82	21.38	24.93	28.48
.94	11 $\frac{1}{4}$	3.64	7.27	10.89	14.51	18.13	21.75	25.36	28.97
.95	11 $\frac{3}{8}$	3.70	7.39	11.07	14.76	18.44	22.12	25.79	29.47
.96	11 $\frac{3}{8}$	3.76	7.51	11.26	15.00	18.75	22.49	26.22	29.97
.97	11 $\frac{3}{8}$	3.82	7.63	11.44	15.25	19.06	22.86	26.66	30.48
.98	11 $\frac{3}{8}$	3.88	7.76	11.63	15.50	19.37	23.24	27.10	30.98
.99	11 $\frac{7}{8}$	3.94	7.88	11.82	15.75	19.68	23.62	27.55	31.49
1.00	12	4.00	8.00	12.00	16.00	20.00	24.00	28.00	32.00
1.01	12 $\frac{1}{8}$	4.06	8.12	12.19	16.25	20.32	24.38	28.45	32.52
1.02	12 $\frac{1}{4}$	4.12	8.25	12.33	16.51	20.64	24.77	28.90	33.04
1.03	12 $\frac{3}{8}$	4.18	8.38	12.57	16.76	20.96	25.16	29.36	33.56
1.04	12 $\frac{1}{2}$	4.25	8.50	12.76	17.02	21.28	25.55	29.82	34.08
1.05	12 $\frac{5}{8}$	4.31	8.63	12.96	17.28	21.61	25.94	30.28	34.61
1.06	12 $\frac{5}{8}$	4.37	8.76	13.15	17.54	21.94	26.34	30.74	35.14
1.07	12 $\frac{7}{8}$	4.43	8.88	13.34	17.80	22.27	26.74	31.20	35.68
1.08	12 $\frac{7}{8}$	4.50	9.01	13.54	18.07	22.60	27.13	31.67	36.22
1.09	13 $\frac{1}{8}$	4.56	9.14	13.74	18.34	22.93	27.53	32.14	36.76

Upper Head H _s		Discharge per second for flumes of various throat widths							
		1	2	3	4	5	6	7	8
		Foot	Feet	Feet	Feet	Feet	Feet	Feet	Feet
Feet	Inches	Cu. ft.	Cu. ft.	Cu. ft.	Cu. ft.	Cu. ft.	Cu. ft.	Cu. ft.	Cu. ft.
1.10	13 ³ / ₁₆	4.62	9.27	13.93	18.60	23.26	27.94	32.62	37.30
1.11	13 ¹ / ₁₆	4.68	9.40	14.13	18.86	23.60	28.35	33.10	37.84
1.12	13 ¹ / ₁₆	4.75	9.54	14.33	19.13	23.94	28.76	33.58	38.39
1.13	13 ¹ / ₁₆	4.82	9.67	14.53	19.40	24.28	29.17	34.06	38.94
1.14	13 ¹ / ₁₆	4.88	9.80	14.73	19.67	24.62	29.58	34.54	39.50
1.15	13 ¹ / ₁₆	4.94	9.94	14.94	19.94	24.96	30.00	35.02	40.06
1.16	13 ¹ / ₁₆	5.01	10.07	15.14	20.22	25.31	30.41	35.51	40.62
1.17	14 ¹ / ₁₆	5.08	10.20	15.34	20.50	25.66	30.83	36.00	41.18
1.18	14 ¹ / ₁₆	5.15	10.34	15.55	20.78	26.01	31.25	36.50	41.75
1.19	14 ¹ / ₁₆	5.21	10.48	15.76	21.05	26.36	31.68	37.00	42.32
1.20	14 ¹ / ₁₆	5.28	10.61	15.96	21.33	26.71	32.10	37.50	42.89
1.21	14 ¹ / ₁₆	5.34	10.75	16.17	21.61	27.06	32.53	38.00	43.47
1.22	14 ¹ / ₁₆	5.41	10.89	16.38	21.90	27.42	32.96	38.50	44.05
1.23	14 ¹ / ₁₆	5.48	11.03	16.60	22.18	27.78	33.39	39.00	44.64
1.24	14 ¹ / ₁₆	5.55	11.17	16.81	22.47	28.14	33.82	39.51	45.22
1.25	15	5.62	11.31	17.02	22.75	28.50	34.26	40.02	45.80
1.26	15 ¹ / ₁₆	5.69	11.45	17.23	23.04	28.86	34.70	40.54	46.38
1.27	15 ¹ / ₁₆	5.76	11.59	17.44	23.33	29.22	35.14	41.05	46.97
1.28	15 ¹ / ₁₆	5.82	11.73	17.66	23.62	29.59	35.58	41.57	47.57
1.29	15 ¹ / ₁₆	5.89	11.87	17.88	23.92	29.96	36.02	42.09	48.17
1.30	15 ¹ / ₁₆	5.96	12.01	18.10	24.21	30.33	36.47	42.62	48.78
1.31	15 ¹ / ₁₆	6.03	12.16	18.32	24.50	30.70	36.92	43.14	49.38
1.32	15 ¹ / ₁₆	6.10	12.30	18.54	24.80	31.07	37.37	43.67	49.99
1.33	15 ¹ / ₁₆	6.18	12.44	18.76	25.10	31.44	37.82	44.20	50.60
1.34	16 ¹ / ₁₆	6.25	12.59	18.98	25.39	31.82	38.28	44.73	51.22
1.35	16 ¹ / ₁₆	6.32	12.74	19.20	25.69	32.20	38.74	45.26	51.84
1.36	16 ¹ / ₁₆	6.39	12.89	19.42	25.99	32.58	39.20	45.80	52.46
1.37	16 ¹ / ₁₆	6.46	13.03	19.64	26.30	32.96	39.66	46.35	53.08
1.38	16 ¹ / ₁₆	6.53	13.18	19.87	26.60	33.34	40.12	46.89	53.70
1.39	16 ¹ / ₁₆	6.60	13.33	20.10	26.90	33.72	40.58	47.44	54.33
1.40	16 ¹ / ₁₆	6.68	13.48	20.32	27.21	34.11	41.05	47.99	54.95
1.41	16 ¹ / ₁₆	6.75	13.63	20.55	27.52	34.50	41.52	48.54	55.58
1.42	17 ¹ / ₁₆	6.82	13.78	20.78	27.82	34.89	41.99	49.09	56.22
1.43	17 ¹ / ₁₆	6.89	13.93	21.01	28.14	35.28	42.46	49.64	56.86
1.44	17 ¹ / ₁₆	6.97	14.08	21.24	28.45	35.67	42.94	50.20	57.50
1.45	17 ¹ / ₁₆	7.04	14.23	21.47	28.76	36.06	43.42	50.76	58.14
1.46	17 ¹ / ₁₆	7.12	14.38	21.70	29.07	36.46	43.89	51.32	58.78
1.47	17 ¹ / ₁₆	7.19	14.54	21.94	29.38	36.86	44.37	51.88	59.43
1.48	17 ¹ / ₁₆	7.26	14.69	22.17	29.70	37.26	44.85	52.45	60.08
1.49	17 ¹ / ₁₆	7.34	14.85	22.41	30.02	37.66	45.34	53.02	60.74
1.50	18	7.41	15.00	22.64	30.34	38.06	45.82	53.59	61.40
1.51	18 ¹ / ₁₆	7.49	15.16	22.88	30.66	38.46	46.31	54.16	62.06
1.52	18 ¹ / ₁₆	7.57	15.31	23.12	30.98	38.87	46.80	54.74	62.72
1.53	18 ¹ / ₁₆	7.64	15.47	23.36	31.30	39.28	47.30	55.32	63.38
1.54	18 ¹ / ₁₆	7.72	15.62	23.60	31.63	39.68	47.79	55.90	64.04
1.55	18 ¹ / ₁₆	7.80	15.78	23.84	31.95	40.09	48.28	56.48	64.71
1.56	18 ¹ / ₁₆	7.87	15.94	24.08	32.27	40.51	48.78	57.06	65.38
1.57	18 ¹ / ₁₆	7.95	16.10	24.32	32.60	40.92	49.28	57.65	66.06
1.58	18 ¹ / ₁₆	8.02	16.26	24.56	32.93	41.33	49.78	58.24	66.74
1.59	19 ¹ / ₁₆	8.10	16.42	24.80	33.26	41.75	50.28	58.83	67.42
1.60	19 ¹ / ₁₆	8.18	16.58	25.05	33.59	42.17	50.79	59.42	68.10
1.61	19 ¹ / ₁₆	8.26	16.74	25.30	33.92	42.59	51.30	60.02	68.79
1.62	19 ¹ / ₁₆	8.34	16.90	25.54	34.26	43.01	51.81	60.62	69.48
1.63	19 ¹ / ₁₆	8.42	17.06	25.79	34.60	43.43	52.32	61.22	70.17
1.64	19 ¹ / ₁₆	8.49	17.22	26.04	34.93	43.86	52.83	61.82	70.86
1.65	19 ¹ / ₁₆	8.57	17.38	26.29	35.26	44.28	53.34	62.42	71.56
1.66	19 ¹ / ₁₆	8.65	17.55	26.54	35.60	44.70	53.86	63.03	72.26
1.67	20 ¹ / ₁₆	8.73	17.72	26.79	35.94	45.13	54.38	63.64	72.96
1.68	20 ¹ / ₁₆	8.81	17.88	27.04	36.28	45.56	54.90	64.25	73.66
1.69	20 ¹ / ₁₆	8.89	18.04	27.30	36.62	46.00	55.42	64.86	74.37
1.70	20 ¹ / ₁₆	8.97	18.21	27.55	36.96	46.43	55.95	65.48	75.08
1.71	20 ¹ / ₁₆	9.05	18.38	27.80	37.30	46.86	56.48	66.10	75.79
1.72	20 ¹ / ₁₆	9.13	18.54	28.06	37.65	47.30	57.00	66.72	76.50
1.73	20 ¹ / ₁₆	9.21	18.71	28.32	38.00	47.74	57.53	67.34	77.22
1.74	20 ¹ / ₁₆	9.29	18.88	28.57	38.34	48.17	58.06	67.96	77.94
1.75	21	9.38	19.04	28.82	38.69	48.61	58.60	68.59	78.66
1.76	21 ¹ / ₁₆	9.46	19.21	29.08	39.04	49.05	59.13	69.22	79.38
1.77	21 ¹ / ₁₆	9.54	19.38	29.34	39.39	49.50	59.67	69.85	80.10
1.78	21 ¹ / ₁₆	9.62	19.55	29.60	39.74	49.94	60.20	70.48	80.83
1.79	21 ¹ / ₁₆	9.70	19.72	29.87	40.10	50.38	60.74	71.11	81.56

Upper Head H _a		Discharge per second for flumes of various throat widths							
		1	2	3	4	5	6	7	8
		Foot	Feet	Feet	Feet	Feet	Feet	Feet	Feet
Feet	Inches	Cu. ft.	Cu. ft.	Cu. ft.	Cu. ft.	Cu. ft.	Cu. ft.	Cu. ft.	Cu. ft.
1.80	21 ⁵ / ₈	9.79	19.90	30.13	40.45	50.83	61.29	71.75	82.29
1.81	21 ³ / ₈	9.87	20.07	30.39	40.80	51.28	61.83	72.39	83.03
1.82	21 ¹ / ₈	9.95	20.24	30.65	41.16	51.73	62.38	73.03	83.77
1.83	21 ¹ / ₈	10.04	20.42	30.92	41.52	52.18	62.92	73.68	84.51
1.84	22 ¹ / ₈	10.12	20.59	31.18	41.88	52.64	63.46	74.33	85.25
1.85	22 ¹ / ₈	10.20	20.76	31.45	42.24	53.09	64.01	74.98	86.00
1.86	22 ¹ / ₈	10.29	20.93	31.71	42.60	53.55	64.57	75.63	86.75
1.87	22 ¹ / ₈	10.38	21.10	31.98	42.96	54.00	65.13	76.28	87.50
1.88	22 ¹ / ₈	10.46	21.28	32.25	43.32	54.46	65.69	76.93	88.25
1.89	22 ¹ / ₈	10.54	21.46	32.52	43.69	54.92	66.25	77.58	89.00
1.90	22 ¹ / ₈	10.62	21.63	32.79	44.05	55.39	66.81	78.24	89.76
1.91	22 ¹ / ₈	10.71	21.81	33.06	44.42	55.85	67.37	78.90	90.52
1.92	23 ¹ / ₈	10.80	21.99	33.33	44.79	56.32	67.93	79.56	91.29
1.93	23 ¹ / ₈	10.88	22.17	33.60	45.16	56.78	68.50	80.23	92.05
1.94	23 ¹ / ₈	10.97	22.35	33.87	45.53	57.25	69.06	80.90	92.82
1.95	23 ³ / ₈	11.06	22.53	34.14	45.90	57.72	69.63	81.57	93.59
1.96	23 ¹ / ₂	11.14	22.70	34.42	46.27	58.19	70.20	82.24	94.36
1.97	23 ³ / ₈	11.23	22.88	34.70	46.64	58.67	70.78	82.91	95.14
1.98	23 ³ / ₈	11.31	23.06	34.97	47.02	59.14	71.35	83.58	95.92
1.99	23 ³ / ₈	11.40	23.24	35.25	47.40	59.61	71.92	84.26	96.70
2.00	24	11.49	23.43	35.53	47.77	60.08	72.50	84.94	97.48
2.01	24 ¹ / ₈	11.58	23.61	35.81	48.14	60.56	73.08	85.62	98.26
2.02	24 ¹ / ₈	11.66	23.79	36.09	48.52	61.04	73.66	86.30	99.05
2.03	24 ¹ / ₈	11.75	23.98	36.37	48.90	61.52	74.24	86.99	99.84
2.04	24 ¹ / ₂	11.84	24.16	36.65	49.29	62.00	74.83	87.68	100.6
2.05	24 ³ / ₈	11.93	24.34	36.94	49.67	62.48	75.42	88.37	101.4
2.06	24 ³ / ₈	12.02	24.52	37.22	50.05	62.97	76.00	89.06	102.2
2.07	24 ¹ / ₂	12.10	24.70	37.50	50.44	63.46	76.59	89.75	103.0
2.08	24 ¹ / ₂	12.19	24.89	37.78	50.82	63.94	77.19	90.44	103.8
2.09	25 ¹ / ₈	12.28	25.08	38.06	51.21	64.43	77.78	91.14	104.6
2.10	25 ¹ / ₈	12.37	25.27	38.35	51.59	64.92	78.37	91.84	105.4
2.11	25 ¹ / ₈	12.46	25.46	38.64	51.98	65.41	78.97	92.54	106.2
2.12	25 ¹ / ₈	12.55	25.64	38.93	52.37	65.91	79.56	93.25	107.0
2.13	25 ¹ / ₈	12.64	25.83	39.22	52.76	66.40	80.15	93.95	107.9
2.14	25 ¹ / ₈	12.73	26.01	39.50	53.15	66.89	80.75	94.66	108.7
2.15	25 ¹ / ₂	12.82	26.20	39.79	53.54	67.39	81.36	95.37	109.5
2.16	25 ¹ / ₂	12.92	26.39	40.08	53.94	67.89	81.97	96.08	110.3
2.17	26 ¹ / ₈	13.01	26.58	40.37	54.34	68.39	82.58	96.79	111.1
2.18	26 ¹ / ₈	13.10	26.77	40.66	54.73	68.89	83.19	97.51	111.9
2.19	26 ¹ / ₄	13.19	26.96	40.96	55.12	69.39	83.80	98.23	112.8
2.20	26 ³ / ₈	13.28	27.15	41.25	55.52	69.90	84.41	98.94	113.6
2.21	26 ¹ / ₂	13.37	27.34	41.54	55.92	70.40	85.02	99.66	114.4
2.22	26 ³ / ₈	13.46	27.54	41.84	56.32	70.90	85.63	100.4	115.3
2.23	26 ³ / ₈	13.56	27.73	42.13	56.72	71.41	86.25	101.1	116.1
2.24	26 ³ / ₄	13.65	27.92	42.43	57.12	71.92	86.87	101.8	116.9
2.25	27	13.74	28.12	42.73	57.52	72.43	87.49	102.6	117.8
2.26	27 ¹ / ₈	13.84	28.31	43.02	57.93	72.94	88.11	103.3	118.6
2.27	27 ¹ / ₈	13.93	28.50	43.32	58.34	73.46	88.73	104.0	119.5
2.28	27 ³ / ₈	14.02	28.70	43.62	58.74	73.97	89.35	104.8	120.3
2.29	27 ¹ / ₂	14.12	28.90	43.92	59.15	74.49	89.98	105.5	121.2
2.30	27 ³ / ₈	14.21	29.09	44.22	59.56	75.01	90.61	106.2	122.0
2.31	27 ³ / ₈	14.30	29.29	44.52	59.96	75.53	91.24	107.0	122.9
2.32	27 ¹ / ₂	14.40	29.49	44.83	60.37	76.05	91.87	107.7	123.7
2.33	27 ¹ / ₂	14.49	29.69	45.13	60.79	76.57	92.50	108.5	124.6
2.34	28 ¹ / ₈	14.59	29.89	45.43	61.20	77.09	93.14	109.2	125.4
2.35	28 ¹ / ₈	14.68	30.08	45.74	61.61	77.61	93.77	110.0	126.3
2.36	28 ¹ / ₈	14.78	30.28	46.04	62.03	78.13	94.41	110.7	127.2
2.37	28 ¹ / ₈	14.87	30.48	46.35	62.44	78.66	95.05	111.5	128.0
2.38	28 ¹ / ₈	14.97	30.69	46.66	62.86	79.19	95.69	112.2	128.9
2.39	28 ¹ / ₂	15.07	30.89	46.96	63.27	79.72	96.33	113.0	129.8
2.40	28 ¹ / ₂	15.16	31.09	47.27	63.69	80.25	96.97	113.7	130.7
2.41	28 ¹ / ₂	15.26	31.29	47.58	64.11	80.78	97.62	114.5	131.5
2.42	29 ¹ / ₈	15.35	31.49	47.89	64.53	81.31	98.27	115.3	132.4
2.43	29 ¹ / ₈	15.45	31.69	48.20	64.95	81.84	98.91	116.0	133.3
2.44	29 ¹ / ₄	15.55	31.89	48.51	65.38	82.38	99.56	116.8	134.2
2.45	29 ³ / ₈	15.64	32.10	48.82	65.80	82.92	100.2	117.6	135.1
2.46	29 ¹ / ₂	15.74	32.30	49.13	66.23	83.45	100.9	118.3	135.9
2.47	29 ³ / ₈	15.89	32.50	49.45	66.65	83.99	101.5	119.1	136.8
2.48	29 ³ / ₈	15.94	32.70	49.76	67.07	84.53	102.2	119.9	137.7
2.49	29 ⁷ / ₈	16.03	32.90	50.08	67.50	85.07	102.8	120.6	138.6
2.50	30	16.13	33.11	50.39	67.93	85.62	103.5	121.4	139.5

Table III, giving the free-flow discharge in second-feet through the Parshall measuring flume for sizes from 1 foot to 8 feet, is based on the formula

$$Q = 4WH_a^{1.522W^{0.026}}$$

Figures 5 and 6 show field installations of 1-foot and 2-foot Parshall measuring flumes operating under free-flow conditions, the latter one being equipped with a water-stage recording instrument giving a record of the upper head, H_a . There is practically no submergence in the case of the 1-foot flume, but in the 2-foot structure the degree of submergence is approximately 50 percent for a discharge of 5.7 second-feet. The loss of head in this structure was determined roughly in the field to be about $4\frac{1}{2}$ inches, and by applying the data to the diagram, figure 18, the loss is calculated to be $5\frac{1}{4}$ inches.

The loss of head, as referred to in this discussion, is taken as the vertical distance in feet between the water surfaces at the upstream and downstream ends of the structure, and does not represent the total loss in head because the velocity heads of the inflowing and outflowing stream through the flume have not been considered.

SUBMERGED-FLOW FORMULA

In the development of a formula suitable for the determination of discharge through the Parshall measuring flume for submerged flow, various methods were attempted, a form of equation being sought that would follow consistently the trend of the data and at the same time not be so complicated as to be impracticable. The following was the manner of reasoning finally followed:

For the degree of submergence below 70 percent, it is found that a simple expression will apply in determining the rate of discharge where only the upper head, H_a , and the width of the flume are involved. However, when the degree of submergence is 70 percent or more the free-flow discharge is diminished slightly at first, and as the degree of submergence increases, the rate of decrease in flow is increased until, near the point of complete submergence, the flow is very greatly reduced. The determination of the rate of submerged flow is then based upon the application of a certain correction to the free flow for that particular head, H_a , and the corresponding ratio of the throat head to the upper head. As pointed out, this ratio must be greater than 70 percent before being effective in the discharge.

The experimental data upon which this correction was first based included the results of 228 tests made in 1923, where the degree of submergence ranged from 70 to more than 95 percent, and a range of H_a from 0.2 foot to slightly more than 2.5 feet. They were divided according to size of flume as follows: 1-foot flume, 46 tests; 2-foot flume, 41 tests; 3-foot flume, 65 tests; 4-foot flume, 21 tests; 6-foot flume, 18 tests; and 8-foot flume, 37 tests. In 1926 a series of sub-

merged-flow tests, numbering 264, was made, and when the results were compared with the original submergence data it was found that a slight adjustment in the correction was necessary. The combination of all the submerged-flow tests shows the following division according to size of flume: 1-foot flume, 80 tests; 2-foot flume, 84 tests; 3-foot flume, 61 tests; 4-foot flume, 64 tests; 6-foot flume, 65 tests; and 8-foot flume, 116 tests. In the final arrangement 21 tests were excluded from the 1923 series.⁹

After reviewing the combined series it was found that for high submergence, where the gage ratio H_b/H_a exceeded 0.95, little dependence could be placed upon the accuracy of the computed discharge; also, when the value of H_a was 0.2 foot, the deviation between the observed and computed discharge was quite large. In the use of a more complicated expression for the determination of the correction factor it would be possible to reduce the error for these low heads, but for the high submergence at any head, H_a , observations show marked inconsistencies.

⁹For the 1-foot flume, test 6494 excluded because H_a exceeded 2.5 feet. Tests 6656-57, 6707-08 excluded because $H_a=0.2$ foot. Tests 6684, 6700, 6705 excluded because submergence exceeded 95 percent. For the 2-foot flume, test 6624 excluded because submergence exceeded 95 percent. Tests 6642-43 and 6646 excluded because $H_a=0.2$ foot; 3-foot flume, test 6583 excluded because submergence exceeded 95 percent; and tests 6579-80-81 excluded because $H_a=0.2$ foot; 6-foot flume, tests 6342 and 7079 excluded because submergence exceeded 95 percent; 8-foot flume, tests 7020-29 excluded because submergence exceeded 95 percent. Of the 471 submerged flow tests falling within the prescribed limits, test 6335 was excluded because of gross error.

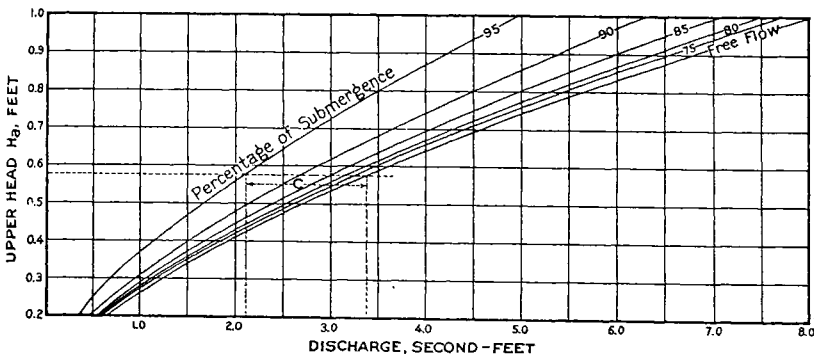

Figure 7.—Meaning of correction factor, C, in second-feet, to be subtracted from the free-flow discharge for a definite value of H_a and a certain degree of submergence.

These data were plotted as shown in figure 7, where the several curved lines represent the degree of submergence. For any particular point on the submergence line there will be a definite value, C , as shown, which is the amount in second-feet to be subtracted from the free-flow value for that particular upper head, H_a , to give the submerged flow. It will be observed that as the value of H_a increases, the amount of the correction also increases for any particular degree of submergence. It is found that for the relation existing between the correction factor, C , for submergence and the upper head, H_a , for any degree of submergence, K , the general expression may be stated thus:

$$C_k = \left\{ \frac{H_a}{A} \right\}^n + B$$

where C_k is the correction in second-feet for the degree of submergence K , expressed as a decimal fraction, and H_a upper head in feet. A and B are values dependent on the gage ratio or degree of submergence, K , and n , an exponent, also depends on K . Base equations were developed for various values of K , ranging from 0.70 to 0.95, and from these the law of variation of A , B , and n was determined. This relation for the 1-foot flume is as follows:

$$C_k = \left\{ \frac{H_a}{\left\{ \frac{1.8}{K} \right\}^{1.8} - 2.45} \right\}^{4.57 - 3.14K} + 0.093K$$

For the other sizes of flume it was found by introducing a multiplying factor to the value of C that a practical agreement with the observed submerged flow was possible. This factor, M , varies with the width or size of flume, W , according to the simple relation $M = W^{0.815}$.

The following is the complete formula for computing the discharge through the Parshall measuring flume for submerged flow:

$$Q = 4WH_a^{1.522}W^{0.026} \left\{ \frac{H_a}{\left\{ \frac{1.8}{K} \right\}^{1.8} - 2.45} \right\}^{4.57 - 3.14K} + 0.093K \left\{ W^{0.815} \right\}$$

This formula is not, in its complete statement, a simple expression; however, when the value of K , the degree of submergence expressed as a decimal fraction, is properly substituted, the formula, or that term representing the correction C , becomes much simplified.

To facilitate the use of this submerged-flow correction formula, the values of C for a 1-foot flume may be taken directly from the diagram, figure 8. To determine the submerged-flow correction for other sizes of flume, multiply this correction by the factor M , as given

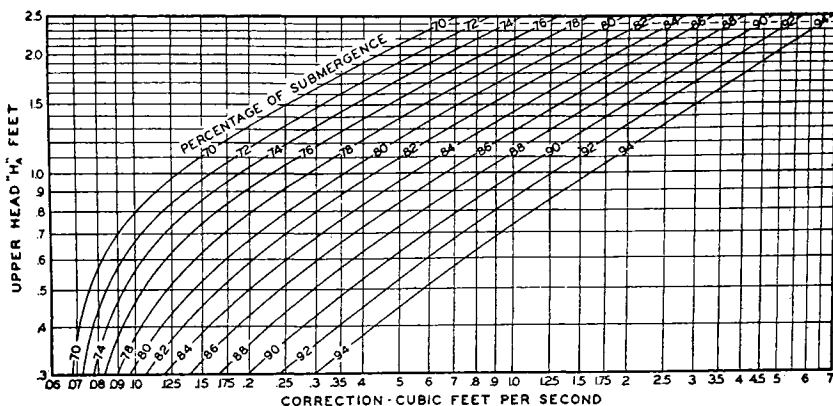

Figure 8.—Diagram for computing submerged flow through 1-foot Parshall measuring flume.

in the following tabulation, before subtracting from the corresponding free flow for that particular H_a head.

Size of flume Width in feet	Multiplying factor	Size of flume Width in feet	Multiplying factor
1	1.0	5	3.7
2	1.8	6	4.3
3	2.4	7	4.9
4	3.1	8	5.4

Figure 9 shows the agreement of the observed and computed discharges for submerged flow. The manner of compiling the data and constructing this diagram is identical with that given for the free-flow discharge. In the comparison of computed and observed discharges for the total 470 tests, it was found that 87 percent were within 5 percent of the observed value.

In the comparison of the free-flow and submerged-flow error diagrams, it is evident that the accuracy of the measurement is greater where the device operates under a free-flow condition.

In determining the rate of discharge through the Parshall measuring flume under submerged flow, the following examples are given to illustrate the method of computation:

(1) Let it be assumed that the flume has a throat width of one foot; upper head, H_a, 1.50 feet; and the throat head H_b, 1.20 feet. The ratio 1.20/1.50 = 0.80. Enter diagram, figure 8, at the left hand side on the H_a line 1.5, follow this horizontal line to the right until reaching the curved line 80. Vertically beneath this intersection observe the reading 0.71, which is the correction in second-feet due to the submergence. In the free-flow discharge, table III, for the 1-foot flume with the recorded head, H_a, of 1.50 feet, note that the discharge is 7.41 second-feet. The flow with a submergence of 80 percent under these conditions will, therefore, be 7.41 — 0.71 = 6.70 second-feet.

(2) What will be the discharge through a 4-foot flume where the upper head H_a is 1.98 feet and the throat head, H_b, is 1.80 feet?

The ratio 1.80/1.98 is very closely 0.91. As before, enter the correction diagram at the left; however, in this case follow to the right along the horizontal line indicating $H_a = 2.0$ until the point is reached midway between curved lines 90 and 92. It is to be kept in mind that the line $H_a = 2.0$ is slightly above the true value of the upper head, which is 1.98 feet. At this corrected point, move vertically downward to the base of the diagram and estimate the value on this scale at 3.50 second-feet, which is the submergence correction for a 1-foot flume. It will be noted in the previous tabulation that the multiplying factor, M , for the 4-foot flume is 3.1. This factor times the correction in second-feet is 10.85 second-feet or the amount to be deducted from the free flow through the 4-foot flume for an upper head H_a of 1.98 feet. The computed submerged flow is therefore 36.17 second-feet.

(3) Suppose the upper head, H_a , of an 8-foot flume is 0.69 foot and the throat head, H_b , is 0.60 foot, what would be the submerged-flow discharge? The ratio of the two heads will be 0.60/0.69 or very closely 0.87. As before, enter the correction diagram at the left and follow horizontally to the right on the line 0.7 to a point about midway between the curved lines "86" and "88". Since the value of the H_a head is 0.69 foot, it will be necessary to select the true point about one tenth the interval below the 0.7 H_a line. Vertically below this final location of the true point there will be found, on the base of the diagram, the value of 0.41 second-foot as the correction for submergence for the 1-foot flume. The multiplying factor, M , for the 8-foot flume will be 0.41 times 5.4 or 2.21 second-feet. The free-flow discharge through the 8-foot flume for an upper head, H_a , at 0.69 foot is 17.63 second-feet. The computed submerged flow will be 17.63 — 2.21 = 15.42 second-feet. For this degree of submergence it is readily determined that the free-flow discharge has been reduced approximately 12.5 percent.

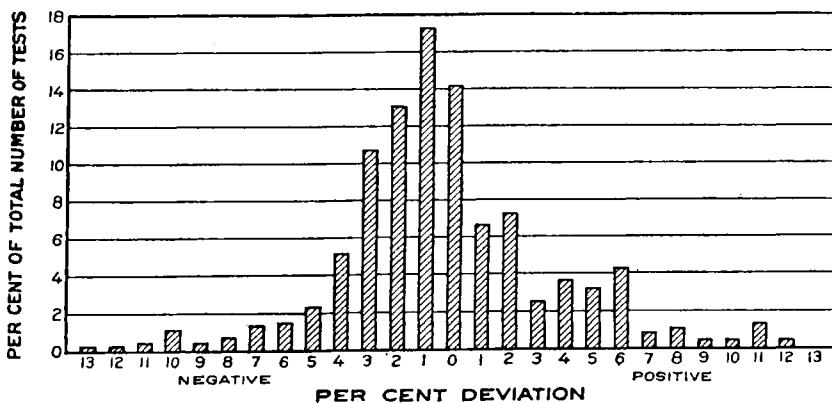

Figure 9.—Comparison in percentage of computed with observed submerged-flow discharge through experimental flumes.

The error in calculating the submerged-flow discharge, resulting from observing either the upper head or the throat head 0.01 foot too large or too small, is found for H_a heads of 0.5 foot and submergences 75 to 90 percent to range from about 1 to 10 percent, while for 95 percent submergence this error may be 20 to 30 percent. For H_a heads of about 2 feet this error for submergences, 75 to 95 percent, would be 5 percent or less.

In order to make a field comparison between the computed discharge of a Parshall measuring flume and an ordinary rating flume, there was built a 6-foot flume in a ditch at Rocky Ford, Colo., as shown in figure 10. This flume was provided with stilling wells for both the H_a and H_b gages. An index was fixed near the top of each well, which made it possible to determine the heads to 0.01 foot by means of a depth gage. Reference points in the upstream and downstream wings of the structure were used to determine the loss of head.

An ordinary rating flume, previously constructed in the ditch at a point about 100 yards downstream, was calibrated by current meter gagings and used to determine the discharge of the Parshall measuring

TABLE IV.—COMPARISON OF COMPUTED DISCHARGE THROUGH A 6-FOOT PARSHALL MEASURING FLUME WITH THAT DETERMINED BY MEANS OF A DISCHARGE CURVE FOR AN ORDINARY RATING FLUME, ROCKY FORD DITCH, ROCKY FORD, COLO.

(The values of H_a and H_b are single observations; that is, they are not the mean of several trials in the determination of these heads.)

Date	Six-foot Parshall measuring flume		Ratio H_b/H_a	Loss of Head	Computed discharge		Rating flume*		Difference	Deviation	Current meter gagings in rating flume**	
	H_a	H_b			H_d	Feet	Sec.-ft.	Feet			Sec.-ft.	Feet
1924	Feet	Feet	Feet		Feet	Sec.-ft.	Feet	Sec.-ft.	Feet	Per cent	Feet	Sec.-ft.
3/29	1.78	1.68	0.10	0.944	42.4	1.40	40.2	+2.2	5.5
3/29	1.73	1.65	.08	.954	0.12	38.6	1.40	40.2	-.16	4.0
3/30	2.16	2.06	.11	.949	.15	56.7	1.83	54.0	+2.7	5.0
4/1	1.77	1.70	.07	.960	38.0	1.43	41.3	-3.3	8.0
4/2	1.26	1.22	.04	.968	.05	0.89	24.9
4/9	2.31	2.21	.10	.957	.18	61.1	1.99	59.5	+1.6	2.7
4/11	2.35	2.20	.15	.936	.17	68.2	2.00	59.7	+8.5	14.2
4/21	2.31	2.21	.10	.957	.18	61.1	1.99	59.5	+1.6	2.7
4/26	1.88	1.77	.11	.941	.11	46.9	1.53	44.3	+2.6	5.9
4/29	1.50	1.44	.06	.960	.02	29.5	1.19	33.8	-4.3	12.7
5/5	1.74	1.66	.08	.954	.11	38.7	1.41	40.5	-1.8	4.5
5/6	1.69	1.64	.05	.970	.10	1.37	39.3	1.40	40.3
5/12	1.84	1.80	.04	.978	.12	1.68	49.1	1.68	48.2
5/29	2.11	2.00	.11	.948	.14	54.8	1.76	51.8	+3.0	5.8	1.76	51.8
7/9	2.62	2.52	.10	.962	.18	2.38	72.5	2.38	73.5
7/10	2.99	2.87	.12	.960	.18	2.70	83.4	2.70	83.2
9/19	2.74	2.62	.12	.957	.14	2.46	75.3
10/6	1.88	1.77	.11	.941	.11	46.9	1.53	44.3	+2.6	5.9
10/8	2.14	2.04	.10	.953	.14	54.7	1.87	55.5	-0.8	1.4
11/26	1.92	1.84	.08	.958	47.1	1.60	46.6	+0.5	1.1
12/2	1.95	1.85	.10	.949	.07	44.9	1.61	47.0	-2.1	4.5
12/3	2.36	2.25	.11	.954	.11	63.7	2.05	61.3	+2.4	3.9
12/4	2.22	2.13	.09	.959	.11	57.0	1.92	57.0	0.0	0.0
12/11	2.17	2.08	.09	.959	.13	54.5	1.85	54.8	-0.3	0.5
1925												
9/28	2.16	2.05	.11	.949	.08	56.7	1.86	55.0	+1.7	3.1

*The gage indicated is the reading at the time the heads were observed on the Parshall measuring flume. The corresponding discharge in second-feet was taken from a mean curve based on the current meter gagings given in this table. This rating flume is located in the same channel as the 6-foot flume.

**Current meter gagings in rating flume in second-feet, with corresponding gage in feet. These gagings made on dates indicated.

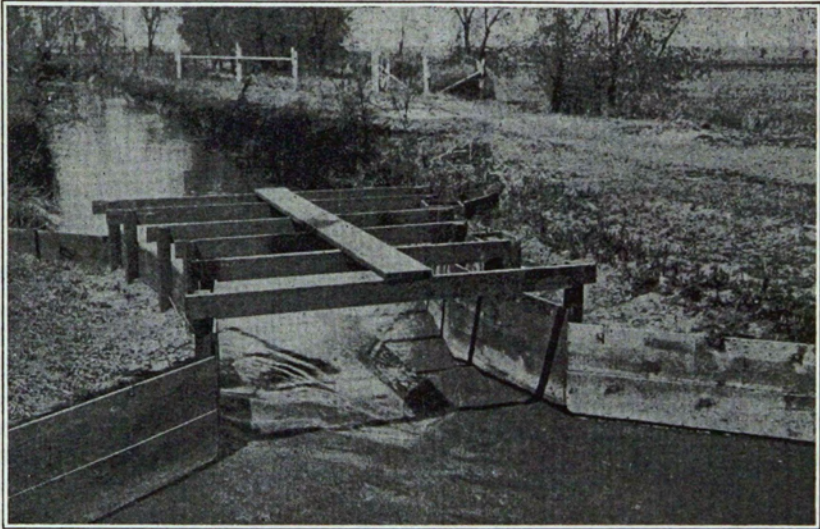

Figure 10.—Six-foot Parshall measuring flume, showing a discharge of 35 second-feet, with a submergence of 95 percent. Rocky Ford, Colo.

flume, but its accuracy was limited to that of the current meter measurements. The condition of flow through the rating flume was satisfactory. Table IV gives a comparison between the computed discharge through this 6-foot flume, and the discharge as shown by the rating flume.

THE 3-, 6-, AND 9-INCH PARSHALL MEASURING FLUME

In the original investigation of this type of measuring device, the 1-foot flume was the smallest size tested, and because of the desirability of using this flume for smaller discharges than could be measured practically by use of the 1-foot size, for both free and submerged flows, calibrations were made on 3-, 6-, and 9-inch flumes having different dimensions than those which governed in the larger sizes. The general dimensions of these small flumes are given in table V. Figure 11 shows the plan and elevation of the 6-inch framed Parshall measuring flume. Figure 12 shows the installation of the 6-inch flume in a farm lateral.

TABLE V.—DIMENSIONS AND CAPACITIES OF THE PARSHALL MEASURING FLUME, FOR THE 3-, 6-, AND 9-INCH CREST LENGTHS

Letters refer to figure 13

W		A		%A		B		C		D		E		F
Inches	Ft.	In.	Ft.	In.	Ft.	In.	Ft.	In.	Ft.	In.	Ft.	In.	Ft.	Ft.
3	1	6 $\frac{3}{8}$	1	$\frac{3}{4}$	1	6	7	10 $\frac{1}{8}$	1	3	10 $\frac{1}{8}$	1	3	$\frac{1}{2}$
6	2	1 $\frac{7}{8}$	1	4 $\frac{1}{8}$	2	10	1	3 $\frac{1}{2}$	1	3 $\frac{1}{2}$	1	6	1	1
9	2	10 $\frac{3}{8}$	1	11 $\frac{1}{2}$	2	10	1	3	1	10 $\frac{3}{8}$	2	1	1	1

W	G	K	N	X	Y	Free-flow Capacity Maximum	Capacity Minimum
Inches	Ft.	In.	In.	In.	In.	Sec.-ft.	Sec.-ft.
3	1	1	2 $\frac{1}{4}$	1	1 $\frac{1}{2}$	1.2	0.03
6	2	3	4 $\frac{1}{2}$	2	3	2.9	.05
9	1 $\frac{1}{2}$	3	4 $\frac{1}{2}$	2	3	5.7	.1

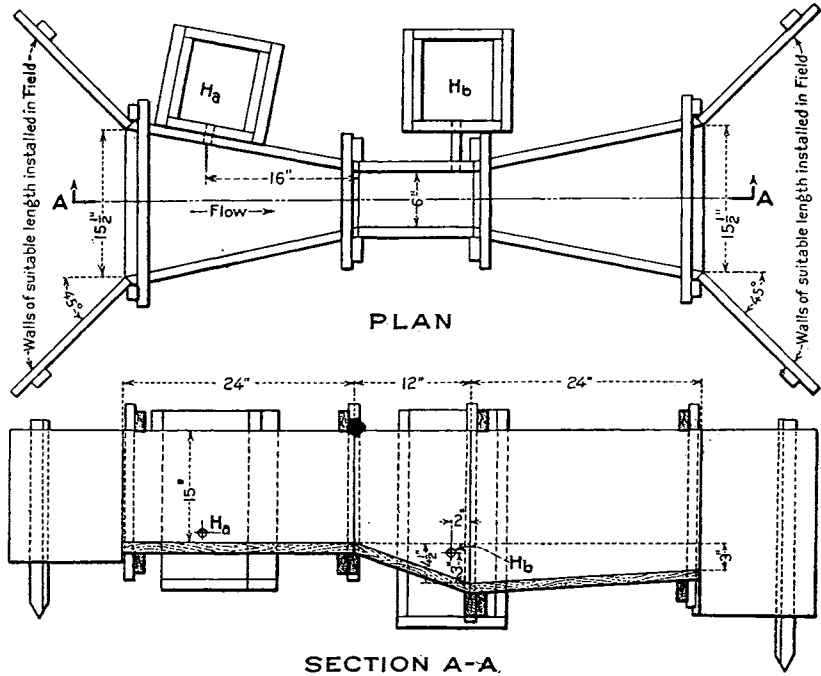

Figure 11.—Plan and elevation of the 6-inch Parshall measuring flume.

TABLE VI.—FREE-FLOW DISCHARGE THROUGH 3-INCH PARSHALL MEASURING FLUME

Based on $Q=0.992 H_a^{1.547}$

Upper head H_a	0.00	0.01	0.02	0.03	0.04	0.05	0.06	0.07	0.08	0.09
Feet	Sec.-ft.	Sec.-ft.	Sec.-ft.	Sec.-ft.	Sec.-ft.	Sec.-ft.	Sec.-ft.	Sec.-ft.	Sec.-ft.	Sec.-ft.
0.10	.028	.033	.037	.042	.047	.053	.058	.064	.070	.076
.20	.082	.089	.095	.102	.109	.117	.124	.131	.138	.146
.30	.154	.162	.170	.179	.187	.196	.205	.213	.222	.231
.40	.241	.250	.260	.269	.279	.289	.299	.309	.319	.329
.50	.339	.350	.361	.371	.382	.393	.404	.415	.427	.438
.60	.450	.462	.474	.485	.497	.509	.522	.534	.546	.558
.70	.571	.584	.597	.610	.623	.636	.649	.662	.675	.689
.80	.702	.716	.730	.744	.757	.771	.786	.800	.814	.828
.90	.843	.858	.872	.887	.902	.916	.931	.946	.961	.977
1.00	.992	1.007	1.023	1.038	1.054	1.070	1.086	1.102	1.118	1.134

TABLE VII.—FREE-FLOW DISCHARGE THROUGH 6-INCH PARSHALL MEASURING FLUME

Based on $Q=2.06 H_a^{1.58}$

Upper head H_a	0.00	0.01	0.02	0.03	0.04	0.05	0.06	0.07	0.08	0.09
Feet	Sec.-ft.	Sec.-ft.	Sec.-ft.	Sec.-ft.	Sec.-ft.	Sec.-ft.	Sec.-ft.	Sec.-ft.	Sec.-ft.	Sec.-ft.
0.10	0.05	0.06	0.07	0.08	0.09	0.10	0.11	0.12	0.14	0.15
.20	.16	.18	.19	.20	.22	.23	.25	.26	.28	.29
.30	.31	.32	.34	.36	.38	.39	.41	.43	.46	.47
.40	.48	.50	.52	.54	.56	.58	.61	.63	.65	.67
.50	.69	.71	.73	.76	.78	.80	.82	.85	.87	.89
.60	.92	.94	.97	.99	1.02	1.04	1.07	1.10	1.12	1.15
.70	1.17	1.20	1.23	1.26	1.28	1.31	1.34	1.36	1.39	1.42
.80	1.45	1.48	1.50	1.53	1.56	1.59	1.62	1.65	1.68	1.71
.90	1.74	1.77	1.81	1.84	1.87	1.90	1.93	1.97	2.00	2.03
1.00	2.06	2.09	2.12	2.16	2.19	2.22	2.26	2.29	2.32	2.36
1.10	2.40	2.43	2.46	2.50	2.53	2.57	2.60	2.64	2.68	2.71
1.20	2.75	2.78	2.82	2.86	2.89	2.93	2.97	3.01	3.04	3.08

TABLE VIII.—FREE-FLOW DISCHARGE THROUGH 9-INCH PARSHALL MEASURING FLUME

Based on $Q=3.07 H_a^{1.53}$

Upper head H_a		0.00	0.01	0.02	0.03	0.04	0.05	0.06	0.07	0.08	0.09
Feet	Sec.-ft.	Sec.-ft.	Sec.-ft.	Sec.-ft.	Sec.-ft.	Sec.-ft.	Sec.-ft.	Sec.-ft.	Sec.-ft.	Sec.-ft.	Sec.-ft.
0.10	0.09	0.10	0.12	0.14	0.15	0.17	0.19	0.20	0.22	0.24	0.24
.20	.26	.28	.30	.32	.35	.37	.39	.41	.44	.46	.46
.30	.49	.51	.54	.56	.59	.62	.64	.67	.70	.73	.73
.40	.76	.78	.81	.84	.87	.90	.94	.97	1.00	1.03	1.03
.50	1.06	1.10	1.13	1.16	1.20	1.23	1.26	1.30	1.33	1.37	1.37
.60	1.40	1.44	1.48	1.51	1.55	1.59	1.63	1.66	1.70	1.74	1.74
.70	1.78	1.82	1.86	1.90	1.94	1.98	2.02	2.06	2.10	2.14	2.14
.80	2.18	2.22	2.27	2.31	2.35	2.39	2.44	2.48	2.52	2.57	2.57
.90	2.61	2.66	2.70	2.75	2.79	2.84	2.88	2.93	2.98	3.02	3.02
1.00	3.07	3.12	3.17	3.21	3.26	3.31	3.36	3.40	3.45	3.50	3.50
1.10	3.55	3.60	3.65	3.70	3.75	3.80	3.85	3.90	3.95	4.01	4.01
1.20	4.06	4.11	4.16	4.22	4.27	4.32	4.37	4.43	4.48	4.53	4.53
1.30	4.59	4.64	4.69	4.75	4.80	4.86	4.92	4.97	5.03	5.08	5.08
1.40	5.14	5.19	5.25	5.31	5.37	5.42	5.48	5.54	5.59	5.65	5.65
1.50	5.71	5.77	5.83	5.89	5.94	6.00	6.06	6.12	6.18	6.24	6.24

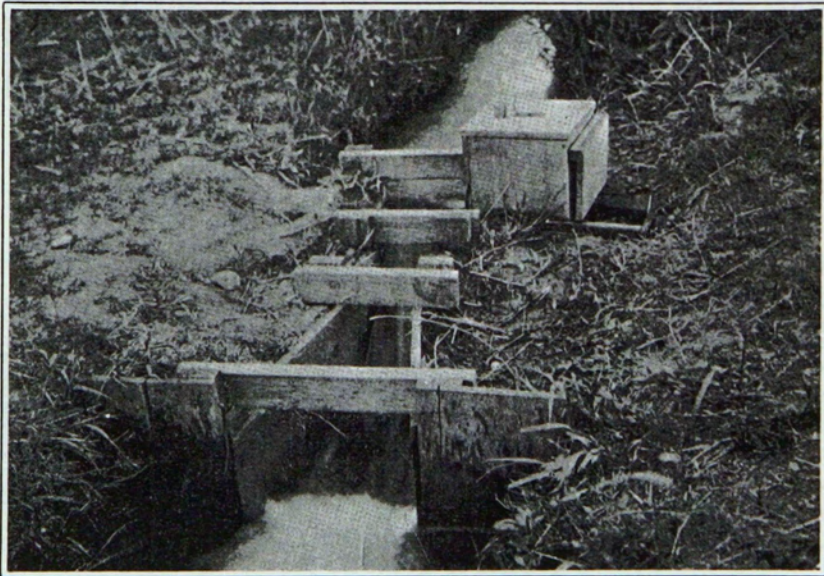

Figure 12.—Free-flow discharge through 6-inch Parshall measuring flume. For small flumes the downstream wings may be at right angles as shown. Installed on farm lateral near Boulder, Colo.

The calibration of these small flumes was made at the Fort Collins hydraulic laboratory. For the 3-inch flume the rate of discharge was determined by volumetric measurements. The 90-degree notch weir was employed in the calibration of the 6-inch flume, while for the 9-inch flume the 2-foot Cipolletti weir and volumetric measurements were used. The upper head, H_a , and throat head, H_b , and the head

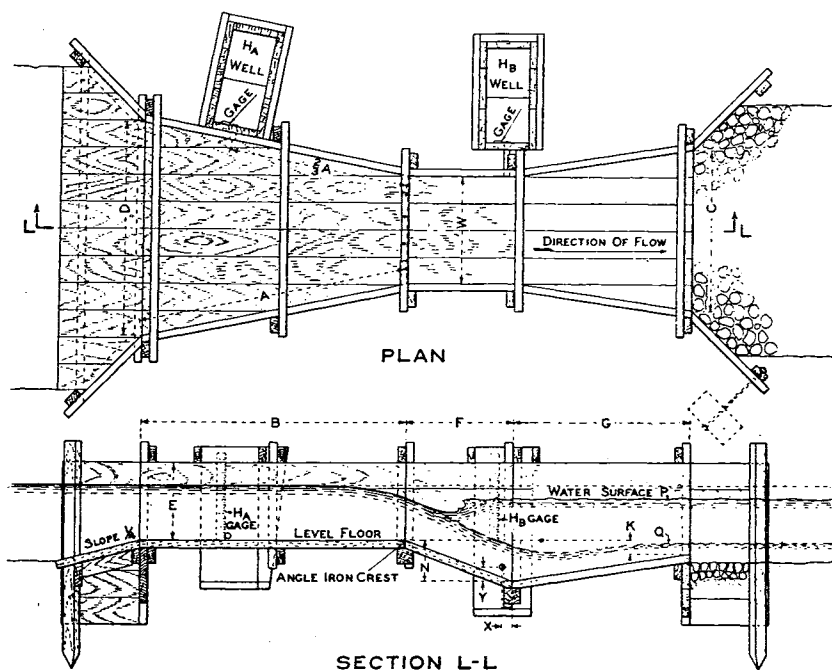

Figure 13.—Plan and elevation of the Parshall measuring flume.

on the weir were ascertained by hookgages reading to 0.001 foot, while the loss of head through the model structures was observed by noting the depths of water above and below the flume, as shown by staff gages having the zero points at the elevation of the level floor or the crest of the device. For the large flumes, the degree of submergence was found to be about 70 percent before the free-flow discharge was affected, while for the smaller flumes the flow was interfered with at about 50 to 60 percent submergence.

From the calibration of the small flumes the following free-flow discharge formulas have been developed:

3-inch flume	$Q = 0.992 H_a^{1.547}$
6-inch flume	$Q = 2.06 H_a^{1.58}$
9-inch flume	$Q = 3.07 H_a^{1.53}$

where Q is the discharge in second-feet and H_a the head taken in feet at the proper gage point in the converging section, as specified in table V. The free-flow discharge in second-feet for the 3-, 6-, and 9-inch flumes is given in tables VI, VII, and VIII, respectively.

No attempt has been made to develop the submerged-flow formulas for the 3- and 9-inch flumes. The computed values of the submerged

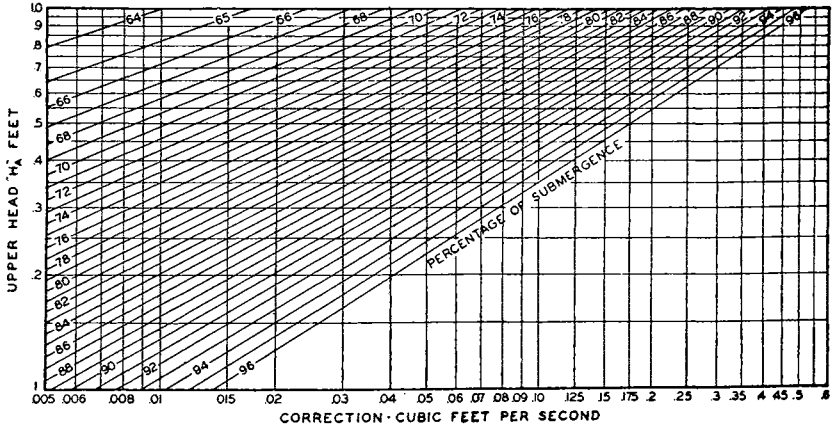

Figure 14.—Diagram for computing submerged flow through 3-inch Parshall measuring flume.

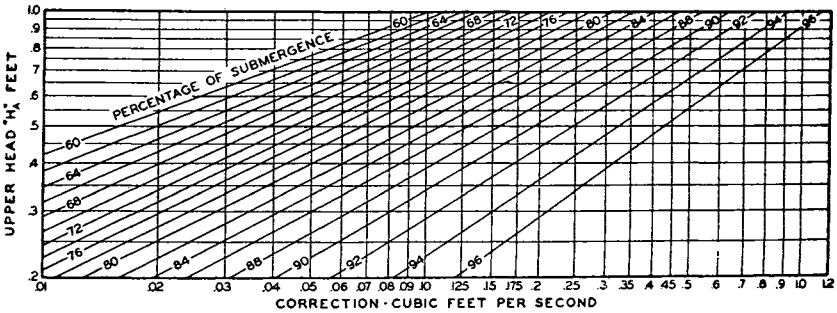

Figure 15.—Diagram for computing submerged flow through 6-inch Parshall measuring flume.

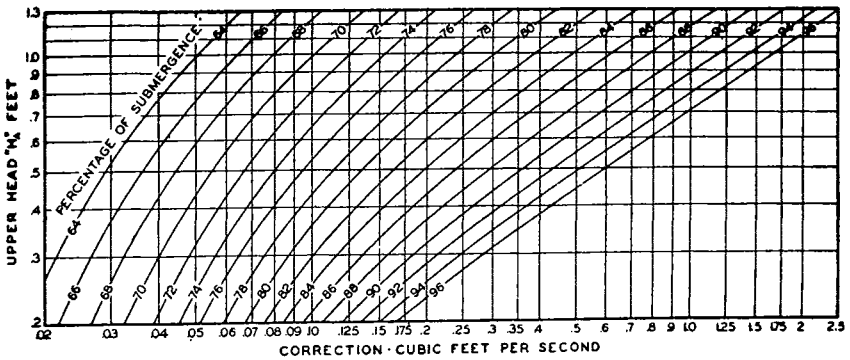

Figure 16.—Diagram for computing submerged flow through 9-inch Parshall measuring flume.

flow for these two small flumes as given in tables XX and XXII were taken from the correction diagrams, figure 14 and figure 16. The computed values of the submerged flow for the 6-inch flume as given in table XXI are based on the formula:

$$Q = 2.06H_a^{1.58} - \left\{ \frac{0.072 H_a^{2.22}}{\left(\frac{H_a + 10}{10} - K \right)^{1.44}} - \frac{H_a - 0.184}{8.17} \right\}$$

where Q = The discharge in second-feet.

H_a = The upper head in feet.

K = The ratio, throat head to upper head, or H_b/H_a expressed as a decimal.

The submerged-flow correction factor, C , for the 6-inch flume is given in the diagram, figure 15.

SELECTION OF THE SIZE OF THE FLUME AND SETTING OF THE STRUCTURE

This device, like any other water-measuring structure, must be properly installed and maintained to give best results. Size must be considered first. Within certain limits of head, any specified discharge

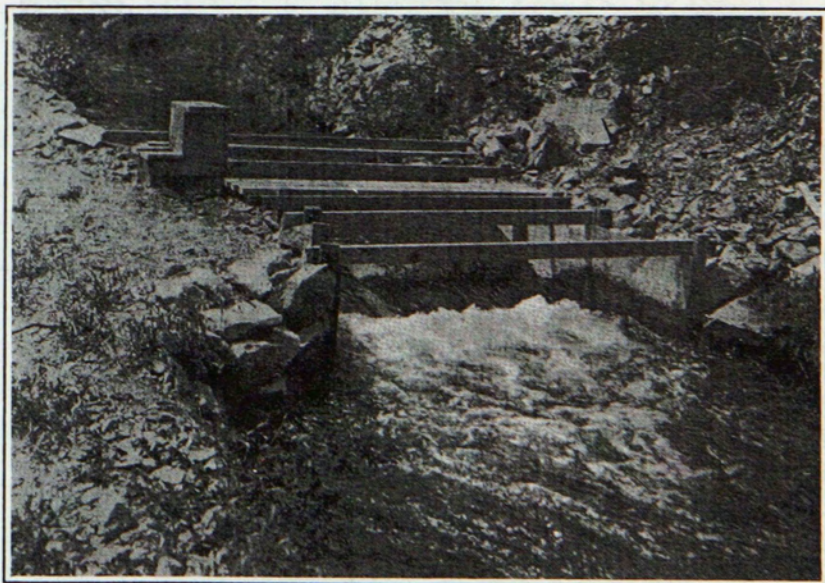

Figure 17.—Six-foot Parshall measuring flume discharging 64 second-feet, with a submergence of 60 percent. Loss of head, 0.8 foot. Farmers Ditch, near Boulder, Colo.

may be measured through flumes of various sizes, and the selection of the proper size to use for the conditions imposed requires careful judgment. From the standpoint of economy, the smaller the flume the less its cost; but to crowd the full discharge through it may require too great a loss of head, which, in turn, would mean greater expense in strengthening the banks of the channel above the structure, as well as providing additional protection to the channel below if the flume is operated under free-flow conditions.

The flume's capacity, or quantity of water to be measured, must first be determined, due allowance being made for additional flow owing to floods or future enlargements of the channel. On the other hand, there is danger in selecting a flume having too wide a throat. If the structure operates under free-flow conditions, the change in upper head for given fluctuations in the discharge will be less for large than for small flumes. It is believed to be the better plan in the operation of large flumes to set the crest elevation so as to have free flow for the low-to-moderate discharges and submerged flow for high

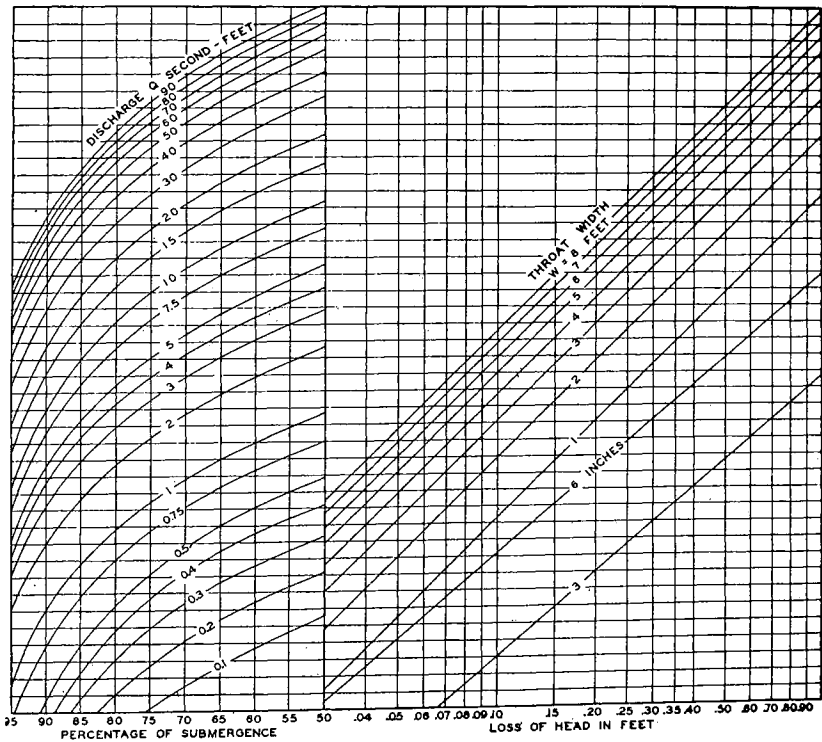

Figure 18.—Diagram for determining the loss of head through the Parshall measuring flume.

discharges. Figure 17 shows a 6-foot flume carrying 64 second-feet, where the loss in head is approximately 0.85 foot and the degree of submergence about 60 percent. This is considered an ideal condition because the degree of submergence is less than 70 percent, the discharge is a function of a single head or depth, and the exit velocity is moderate.

To assist in the selection of the proper size of flume to meet certain requirements, the diagram shown in figure 18 is given. The use of this diagram may best be illustrated by an example: Let it be required to find the loss of head through a 2-foot flume operating at a submergence of 85 percent and discharging 20 second-feet of water. Enter the diagram at the lower left and follow vertically on the line 85 until the curved discharge line 20 is reached. At this point move horizontally to the right until the sloping line 2 is intersected and then drop vertically to the base line and note the loss of head to be 0.33 foot. This loss of head, as previously explained, is the vertical distance in feet between the water surface above and below the structure.

The following discussion is presented citing a practical case such as would be found in the field in selecting the size and setting of the Parshall measuring flume best suited to meet the following requirements: Assume that the channel is 10 feet wide, with the inside slope

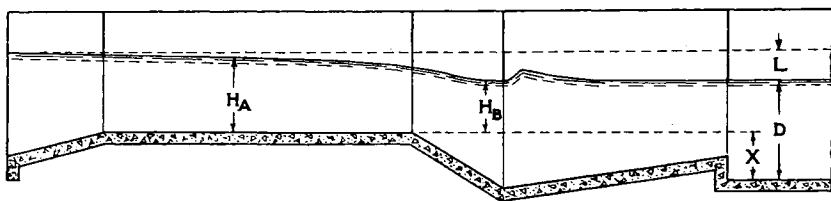

Figure 19.—Section of flume as an aid in the determination of the proper crest elevation.

of the banks 1 to 1, the depth of water 2 feet, and the maximum discharge to be measured 50 second-feet. It is required to select the proper size of flume, to determine its proper setting in elevation with reference to the grade of the channel, and to approximate the condition of flow upstream from the flume after it has been installed.

Generally, the width of the throat of the flume will be from one third to one half the width of the channel; however, for wide, shallow channels or deep, narrow ones this general statement would not hold. The size of channel, depth of water, extent of free board, together with other limiting factors, must all be considered in the final selection of the most practical size of structure. For the 10-foot channel, as assumed, the proper width of throat will probably be 3, 4, or 5 feet.

From the diagram, figure 18, for the 3-foot flume operating at a limiting submergence of 70 percent and a discharge of 50 second-feet, it will be noted that the loss of head through the structure will be 0.86

foot or about $10\frac{1}{4}$ inches. For this condition of flow the depth of water upstream from the flume, when discharging 50 second-feet, will be 0.86 foot greater than that downstream, or a total of 2.86 feet. On this basis it will be necessary to examine the matter of a safe, free board for that portion of the channel upstream from the flume, as well as to determine whether or not this increase in depth will interfere with diverting the flow through the headgates if the location of the flume is near the point of diversion. If a submergence of 90 percent is taken as the limit, then the loss of head will be reduced to about 0.32 foot. It is to be pointed out for the case of this high submergence that both the H_a and H_b heads will have to be observed in order to compute the discharge, whereas, for the submergence of 70 percent only the H_a head would be required.

Investigating a 4-foot flume setting for 70 percent submergence and a discharge of 50 second-feet, it is found from the diagram that the loss of head will be 0.70 foot or about $8\frac{1}{2}$ inches. The loss of head through the 5-foot flume for these same conditions will be 0.60 foot or about $7\frac{1}{4}$ inches. Comparing these values of loss of head, it will be noted that by increasing the size of flume from 3 to 5 feet the loss of head decreased from .86 to .60 foot or about 3 inches. It is usually found that the saving of an inch or so in the loss of head does not warrant the selection of the larger flume, because of the increased cost of the structure. It is recommended in the selection of the proper size of flume that a submergence of 60 percent be taken as the more practical limit to use in approximating the size of structure, provided it is intended to operate the flume as a single-head device. For this degree of submergence, a moderate range in the fluctuation of the depth of water downstream from the flume may be tolerated without exceeding the free-flow limit of submergence of 70 percent.

It appears that the use of the 3-foot flume would result in too great a loss of head; and by the use of the 5-foot flume, when operating under like conditions of a flow of 50 second-feet and 70 percent submergence, a saving in loss of head of 3 inches would be gained. In either case this saving of 3 inches may not be of any great importance, whereas, the cost of the 3- and 5-foot flumes would differ materially. If conditions will permit, it is obvious that the 3-foot structure should be selected, primarily from a cost standpoint. However, it must be appreciated that, when passing 50 second-feet through a throat 3 feet wide, the velocity of the stream would be relatively high and adequate protection against scour downstream from the structure would be required. As the size of flume increases the loss of head will decrease, and likewise the velocity of the stream through the throat will be less. If the 8-foot flume was considered, the loss of head would be reduced to slightly less than 6 inches, and the velocity likewise lessened; but the saving in loss of head probably would not warrant

the extra expense of construction. The 3-foot flume, unless conditions of operation are well suited, may be considered too small, because of the greatest loss of head and maximum scouring effect. The 5-foot flume probably will be more acceptable because of the lesser loss in head and the more favorable velocity through the throat. The 8-foot flume from the standpoint of loss of head and velocity through the structure is the best suited, but because of the greater cost would be found objectionable, and therefore the smaller flume would be selected as a more practical size.

The setting of the flume to the proper elevation with respect to the channel is a matter of importance in order to have the device operate as previously discussed. From table III the H_a head for a free-flow discharge of 50 second-feet through a 5-foot flume is found to be 1.78 feet. Since the degree of submergence is taken as the ratio, H_b/H_a , it is readily determined that the H_b gage reading would be about 1.25 feet for this limiting submergence of 70 percent. In figure 19 is shown the depth, D , or water depth downstream from the structure. This depth minus the value of H_b will give the elevation of the crest above the bottom of the channel. For this particular case, this elevation will be $2.00 - 1.25$ or 0.75 foot. The crest of the 5-foot flume set 0.75 foot or 9 inches above the bed of the channel will increase the water depth upstream about 7 inches.

Conditions of the channel or limiting restrictions of operation may in some cases require that the discharge through the flume be submerged. It has been found by experiment that the degree of submergence should not exceed about 95 percent, and it may therefore be necessary to determine very carefully the crest elevation of the structure in order to limit the submergence at a point not to exceed 95 percent.

After having fully decided upon the location of the flume, its size, and the elevation of the crest which will insure that the flume will operate at free flow or some predetermined degree of submergence, consideration must be given to the fixing of the longitudinal axis of the structure. The site of the flume should be in a reasonably straight section of the channel. It is suggested that a stake be set in the middle of the channel 100 feet upstream, and another at the same distance downstream, from the proposed site. Reference points then should be established at convenient distances near the two ends of the structure and in line with the two more distant points. A line stretched between the two latter points will locate the axis of the flume or the mid-points of the floor sills. For structures of moderate size carrying less than 50 second-feet, possibly no great pains need be taken to have the structure carefully aligned, but for greater discharges care must be taken, in order that the flow below the structure will tend to be more uniformly distributed throughout the channel.



Figure 20.—One-foot reinforced concrete Parshall measuring flume set in close proximity to farm lateral headgate. Free-flow discharge of 2.53 second-feet. Lake Canal, near Fort Collins, Colo.

Ordinarily, when using Parshall measuring flumes of the smaller sizes to measure farm deliveries, it is recommended that the device should not be placed too close to the turn-out gate. However, because of very limited or cramped conditions, such flumes have been located close up to the headgate as shown in figure 20. In this case a 1-foot concrete flume on the Lake Canal, near Fort Collins, was set where the upper end of the converging section is about 12 feet downstream from the headgate. This flume has operated very satisfactorily.

CONSTRUCTION OF THE FLUME

The building of this structure should offer no great difficulty. No warped surfaces have been introduced into the design other than a suggested curved entrance at the inlet of the large flumes. These structures may be made of lumber, concrete, or sheet metal.

Figure 1 suggests a wooden framing for the larger flumes, while for the smaller sizes figure 11 illustrates a practical design in which the walls and floor are of 1-inch or 2-inch material, and the sills, posts, and ties of 2- by 4-inch pieces. Two-inch commercial lumber is recommended for the floor and walls of the larger flumes, while the sills and posts may be of 4- by 4-inch pieces or heavier, as conditions warrant. In the building of the framed structures it is suggested that the pieces which compose the floor and walls be laid with sufficient space between them to allow for swelling when wet, as otherwise the swelling may

be sufficient to warp the surfaces seriously and interfere with the proper functioning of the device. Ordinarily, if the cracks between the planks or boards are $\frac{1}{8}$ to $\frac{3}{16}$ inch wide, the swelling will not cause distortion and yet will make a tight joint.

Let it be assumed that the elevation of the crest of the flume has been fixed by the characteristics of the channel in which the flume is to be built. It is then necessary to set the crest sill at its proper elevation, as well as in the correct transverse position. For the smaller sizes, the fact that the longitudinal axis of the structure is not exactly coincident with that of the channel is of little importance where only moderate flows have to be cared for, but the large flumes should be so set that this axis is approximately correct to permit the stream to approach and leave the structure without undue distortion. Hence the site of the flume should not be in a decided bend of the channel.

The crest sill having been set and securely fixed in position, the other floor sills may be placed at their proper intervals and elevations, after which the posts and ties may be set. The posts must be set back the thickness of the wall to give the flume its proper inside width when completed. The walls of the structure may then be secured to the vertical posts.

The walls of the converging section are of straight framing. Two methods may be used in cutting the pieces for the throat walls. One is shown in figure 1, where the pieces are rectangular and the cracks

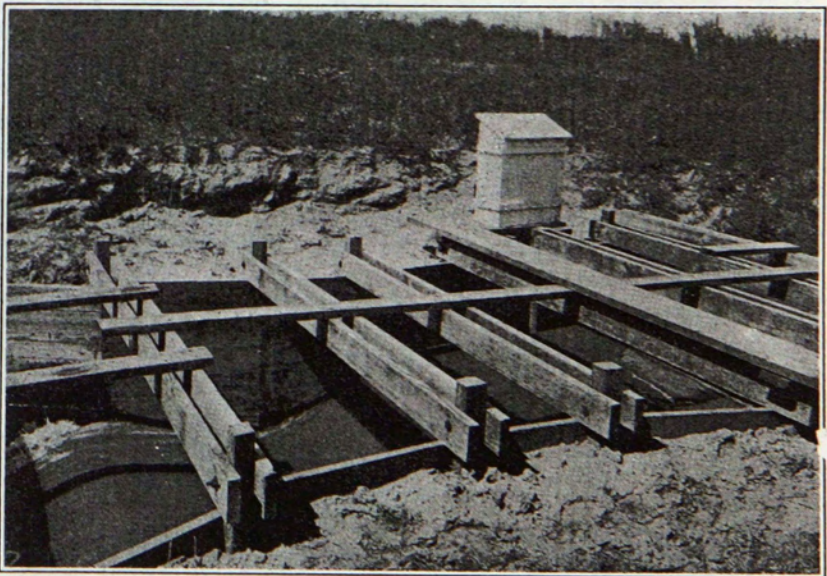

Figure 21.—Eight-foot framed Parshall measuring flume on Box Elder Creek, near Fort Collins, Colo.

between them horizontal. If it is desired to have the cracks parallel the slope of the floor, the pieces composing the throat walls would be cut as parallelograms, with the end cuts on a skew of the ratio 9/24. As the top of the wall will then have a slope equal to that of the floor, the downstream end will be low by 9 inches. If the flume is to be operated under free-flow condition, the height of walls in the diverging section may be less than the converging or upstream part; and, therefore, the top of these walls may be made to agree with the low point of slope of the throat wall. This method of building will reduce the amount of material in the structure. It is suggested, however, that the bottom pieces in the walls of the downstream or diverging section be so cut that the top edges will be level, thus leaving the finished top horizontal. A typical 8-foot framed Parshall measuring flume is shown in figure 21.

After the walls have been placed, the floor is laid. Since the floors of the upstream and downstream sections taper, special pieces will need to be cut to fit. The lower end of the level floor, which forms the crest, should be smooth and even. At this point the throat floor is joined and the pieces forming this inclined floor should be cut on a bevel of 9/24, which will fit closely to the ends of the level floor. It is desirable to use an angle-iron crest for the framed structure. This metal piece is to be dapped in at the downstream end of the level floor of the converging section and made flush with the floor line. This should be set before placing the throat floor. The placing of the floor after the walls have been set holds the bottom course of the walls in position and prevents the outside earth pressure from dislodging or crowding the walls and altering the inside dimensions. The tendency of the larger wooden structures to float should be given consideration, and it is recommended that posts or piling be driven down to tie the sills securely. The cut-off walls set at each end of the structure will aid in holding the flume in place. A plank laid along the outside of the flume walls on the ends of the sills will resist the uplift after back-filling has been placed. Where the discharge through the flume is 50 second-feet or more, the contraction effect set up by the water entering the flume where the 45-degree wings are attached causes a disturbance. A better entrance condition is secured by setting these wings back from the flume and then joining them to it by a sheet metal section rolled to a radius of 30 to 60 inches. The downstream 45-degree wings may be attached directly to the structure.

For moderate flows through the smaller flumes, the downstream wings may be placed at right angles to the axis of the flume, as shown in figure 12. For the larger discharges, some protection to the bottom of the channel immediately upstream from the flume may be necessary. Large flat stones or heavy gravel would, under ordinary conditions, provide ample protection. For free-flow conditions, the exit velocity

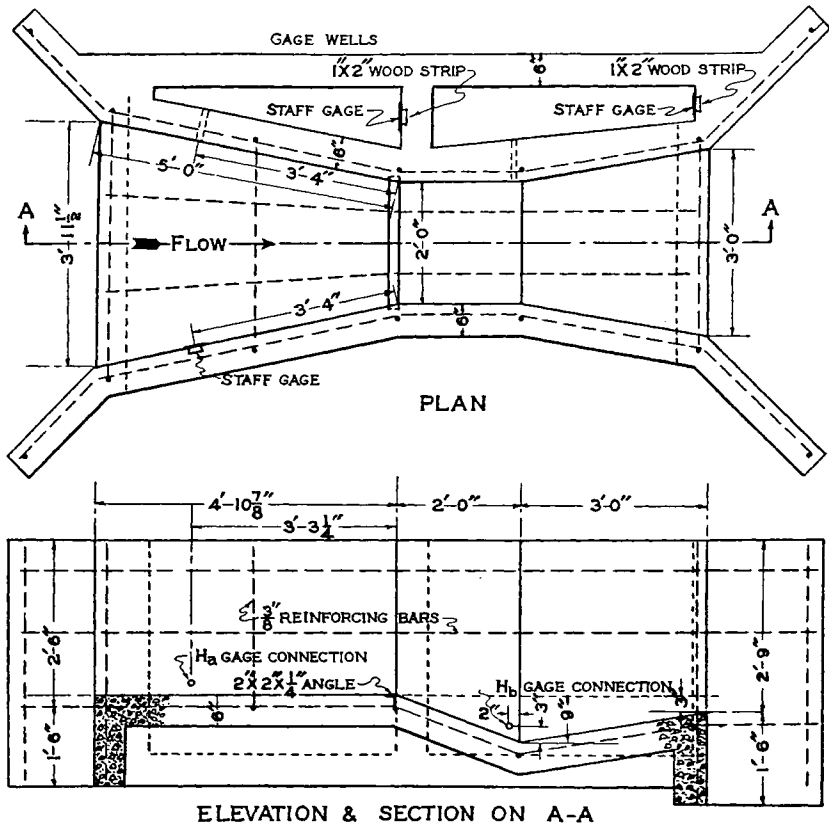

Figure 22.—Plan and elevation of a 2-foot reinforced concrete Parshall measuring flume.

is quite high, and where the channel is in earthy section, ample protection must be provided. To prevent bottom scour, a wire mattress filled with cobblestones and brush has been used successfully. This mattress is attached to the lower end of the structure and laid transversely to the axis of the channel. The top and bottom webs of the mattress should be securely wired together. These vertical wires will prevent the material within the mattress from collecting at the lower side. Being flexible, the mattress will sag down if any cutting occurs and form a protection for the lower end of the structure. Bank protection may be provided in the same manner downstream from the outlet of the flume.

The Parshall measuring flume may be constructed of concrete, as suggested in the plan shown in figure 22. The construction of concrete flumes is similar to that of any ordinary reinforced structure. Because of the flume's relatively short length, it is not necessary to

provide expansion joints; but to increase stability, braces may be added to tie the walls at the top. As the crest of the flume is an important part of the structure, it is suggested that an angle-iron be cast in the floor at this point, with its top face flush with the plane of the level floor, the corner of the angle-iron forming the true crest. The stilling wells for the concrete flumes may be of either wood or concrete, and since the water level in the well is the real index to the water surface within the flume itself, it is essential that the leakage be a minimum to insure the correct reading of the effective depth. Wooden stilling wells carefully made, when once tight after swelling, are dependable but can not be expected to last indefinitely. Wells of small cross-section are impractical, because of the difficulty experienced in cleaning them. They should be of ample size, with the side opposite the flume sloping outward at the top to permit easy cleaning, as well

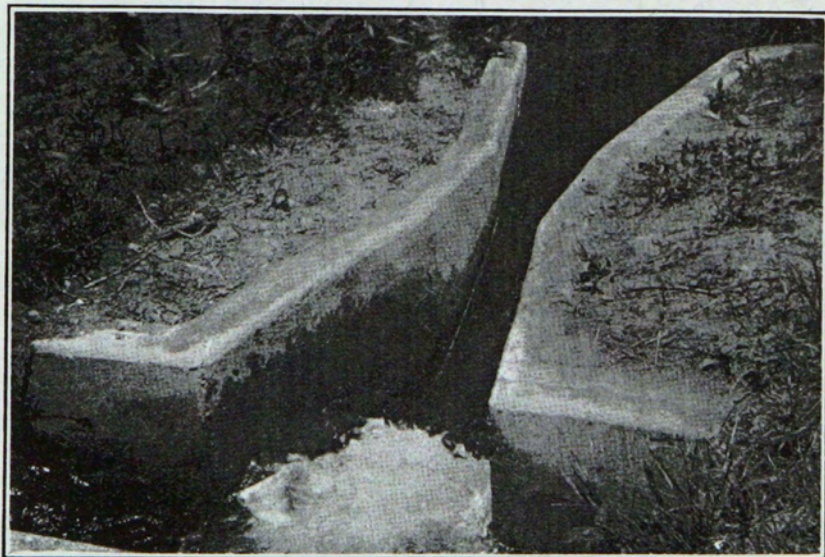

Figure 23.—One-foot reinforced concrete Parshall measuring flume, free-flow discharge of 4 second-feet. Lake Canal, near Fort Collins, Colo.

as for easy and accurate reading of a staff gage set on the far side of the well, as shown in figure 1. A typical reinforced concrete flume is shown in figure 23.

For the 3-, 6-, 9-, or 12-inch flumes, where a number are to be installed, precast concrete members may be made and installed in the field. To accomplish this, the design for the casting of the several pieces must be such that each will not be too heavy to be handled conveniently. It is recommended that the floor of the converging or

upstream section, and the floor of the throat section, be cast as one piece, with a light angle-iron cast into the face at the crest. A rib should be cast longitudinally along the center line on the bottom side to strengthen the members while they are being handled, and a groove should be formed at the proper distance along the sides, top face, to locate and fix the position of the side walls. Each of these side walls should be cast as a flat slab of the proper dimensions, with a projecting tongue on the sides to engage the grooves of adjacent members. Stub bolts cast into the top face of wall members will fix crossbars or struts to resist displacement after the structure has been assembled. Tubes should be cast at the proper points, both in the converging and throat walls, to which stilling wells may be attached for the measurement of heads. The wells may be made of lumber (figs. 1 and 11) set to fit the tube connections, or for moderate depths of flow they may be of ordinary sewer tile set into a concrete base, with the connecting tube reaching through a hole in the side. (Sections of old stave pipe may be used as stilling wells.) This arrangement will not permit the use of a vertical scale in the tile or pipe to determine the head, but a scale measuring down to the water surface from a fixed point at the top may be used. This distance subtracted from the elevation of the fixed point above the crest of the flume will give the effective head.

In building a concrete flume in place, a suitable foundation is first prepared in the bottom of the channel. The forms for the floor are set to a grade such that, when struck off, the floor of the converging section is level, and the floor of the throat and diverging section have properly inclined slopes. For all structures built in a channel, it is necessary to guard against the possibility of the water washing beneath the structure. It is recommended that in preparing the foundation a trench be cut crosswise, which, when filled with concrete, will form a cut-off wall at each end of the structure and be made a part of the floor itself; and that the concrete wings be set down deep enough and into the banks far enough to prevent the water from cutting around the sides. The lower parts of the wing walls should be cast at the same time as the floor system. In building small structures, before the concrete sets, short pieces of reinforcing bars or scrap-iron may be placed at intervals along the edges of the floor in such manner that when the walls are cast they will strengthen the structure against possible cracking or rupturing at the floor line. After the floor has set hard enough to permit work to be done on it, the forms for the side walls are placed and braced securely to prevent possible displacement. Before the walls are poured, the surface of the floor which is in contact with the new wall should be cleaned thoroughly in order that a proper bond may be secured.

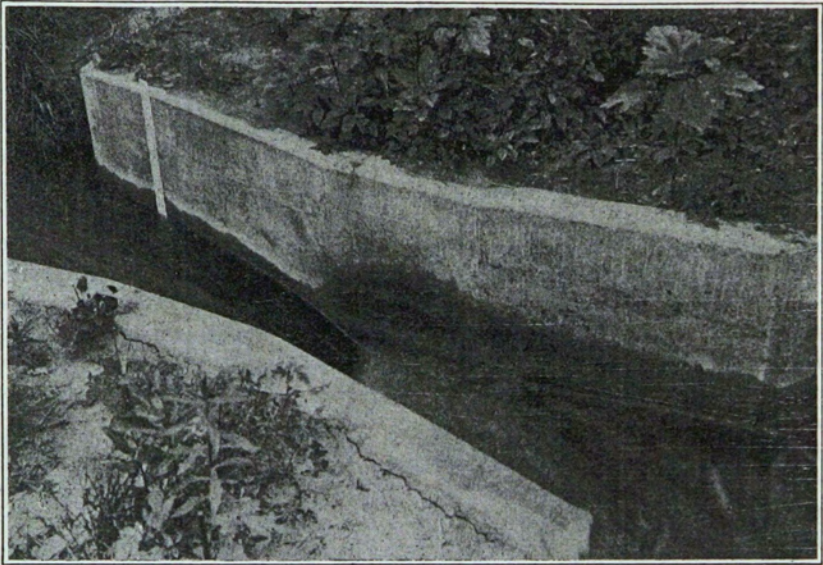

Figure 24.—Three-foot reinforced concrete Parshall measuring flume discharging about 13 second-feet. Kern lateral, Lake Canal system, near Fort Collins, Colo.

Figure 24 shows a flow of 13 second-feet passing through a 3-foot concrete flume at a submergence of about 50 percent. Where the flow is not submerged it has been found a practical expedient for small flows to place the H_a staff gage at the proper point on the wall of the converging section as shown. Figure 25 also shows a 3-foot concrete flume operating at a submergence of about 50 percent.

The smaller sizes of flumes may be made of sheet metal, as shown in figure 26. This 6-inch flume was assembled in the shop ready for setting in the field. It was built rigidly of 16-gage galvanized sheet steel, and exclusive of the stilling well, weighed 65 pounds.

Small flumes built of galvanized sheet metal or of heavy, rust-resistant black iron have long life, are easy to set, may be readily moved and relocated, can not be harmed by burning weeds or trash in ditch-cleaning operations, do not leak, and are easily built true to specified dimensions. The metal flume has been used in sizes up to 4 feet. Figure 27 shows a 3-foot metal Parshall measuring flume installed on the outlet of one of the main sewer lines of the city of Colorado Springs.

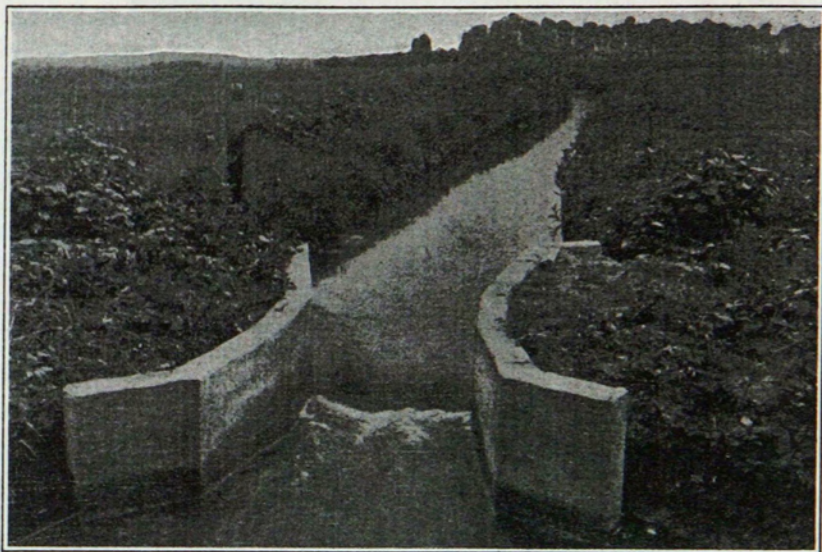

Figure 25.—Looking upstream through a 3-foot reinforced concrete Parshall measuring flume. Free-flow discharge of 11.4 second-feet. Lake Canal, near Fort Collins, Colo.

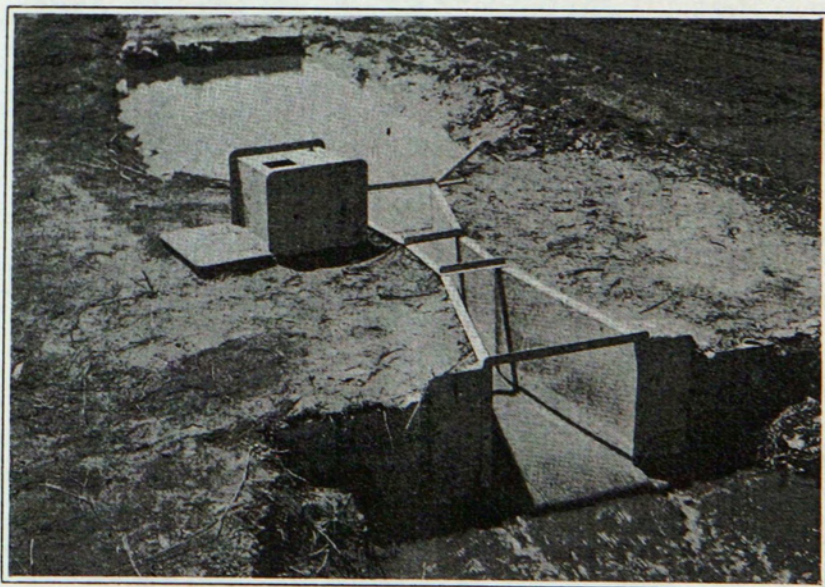

Figure 26.—Six-inch Parshall measuring flume constructed of sheet metal. Typical field installation on farm lateral.

EFFECT OF VELOCITY OF APPROACH ON THE ACCURACY OF MEASUREMENT

To test the effect of velocity of approach, a series of observations was made on the 2-foot flume at the Bellvue laboratory. The floor of the channel immediately above the flume structure was built level, of 1-inch boards, this floor being in reality merely an extension of the floor of the converging section of the experimental flume. Vertical wing walls were placed at an angle of 45 degrees to the longitudinal axis of the flume from the upper ends of its converging section, these wings extending back on each side to the concrete walls of the laboratory channel. Movable partitions were set up in a vertical position on the floor of the approach section, one on each side of and parallel to the axis of the channel, with the lower or downstream ends against the wings. Tests were made with widths of approach channel varying from a maximum of 11.1 feet to a minimum of 6.0 feet. In 1932 further tests were made in the laboratory on the standard 2-foot Parshall measuring flume, where these movable partitions were set with the downstream ends against the upstream ends of the converging section or set apart 3.96 feet. The results of this entire series of observations for free flow are given in table IX.

In the last column of this table, showing ratio of velocities in percentages, it appears that for the narrow channel, about 4 feet in width, the velocity of approach is practically three times that for the standard condition of 11.1 feet. To determine these values, the velocity of approach in feet per second was carefully plotted against the upper head, H_a , where the width of channel was 11.1 feet. The mean curve was drawn through these points, which gave the values near 100 percent as indicated. Then for the other widths of channel, the velocity of approach for the corresponding head was determined from this mean curve, and this value was compared with the actual velocity of approach. These tests indicate that the maximum increase to about 300 percent in velocity of approach does not cause a significant change in the discharge, as the variation is less than the experimental error.

The Parshall measuring flume is primarily intended to operate under conditions where the velocities are moderate. There may be cases where the channel in which the measurement is to be made has a relatively steep grade or narrow section, and the velocity of the flowing water is considerably above that ordinarily encountered. The converging section of the flume through which the water passes in approaching the throat automatically controls the velocity of the stream as it flows over the crest of the device, providing the approaching stream to the structure shall be flowing at streaming stage or less than the critical velocity. This implies that the grade of the channel leading to the structure shall be reasonably gentle. However, if conditions are such as to cause high velocities of the approaching stream, then a

flume of narrow throat width should be installed whereby the depth of the water would be increased and the velocity of the stream reduced. An extreme case might be assumed in which the channel is 5 feet wide, the side slopes are 1 to 1, the water is 1 foot deep and flows at a mean



Figure 27.—Three-foot metal Parshall measuring flume discharging about $5\frac{1}{2}$ second-feet. Sewer outlet, city of Colorado Springs, Colo.

velocity of 6 feet per second. For this assumption the discharge would be 36 second-feet. The use of a 6-foot flume to meet such a condition would be found inadequate, because the control of the converging section would be ineffective. For this a 3-foot flume would meet conditions, because then the control would become operative and cause the water at the upstream end of the flume to assume a depth of 2.10 feet, with a velocity of 3.34 feet per second. In the approach channel the water would be 2.10 feet deep and the velocity reduced to 2.41 feet per second, which would be satisfactory.

The effect on the discharge over standard weirs caused by filling the basin upstream from the crest with sediment or deposit, or reducing this depth by improper construction, possibly may not be fully appreciated. For proper measurement by the use of the standard overpour weir, it has been found by experiment that the bottom depth, or vertical distance from the crest to bottom, should equal twice the maximum head, and the distance out to the sides of the box or banks be equal to three times this head; or the bottom depth be three times the head and the side or end distance be twice the head. With these

TABLE IX.—EFFECT OF VELOCITY OF APPROACH ON DISCHARGE THROUGH 2-FOOT PARSHALL MEASURING FLUME

H _a Feet	Discharge		Difference Sec.-ft.	Deviation Percent	Area water prism channel of approach Sq. ft.	Velocity in channel of approach Ft. per sec.	Ratio of velocities Percent
	Observed	Computed					
Width of approach channel, 11.1 feet							
2.65	35.84	36.23	-0.39	-1.1	32.2	1.11	100
2.56	33.48	34.34	-0.86	-2.5	31.2	1.07	101
2.52	33.03	35.52	-0.49	-1.5	30.8	1.07	101
2.52	33.43	33.52	-0.09	-0.3	30.1	1.11	103
2.35	29.94	30.08	-0.14	-0.5	28.8	1.04	100
2.09	25.03	25.08	-0.05	-0.2	25.6	0.98	100
1.79	19.90	19.72	+0.18	+0.9	21.9	0.91	100
1.53	14.90	15.47	-0.57	-3.8	18.4	0.81	103
1.51	15.12	15.08	+0.04	+0.3	18.2	0.83	101
1.13	9.59	9.67	-0.08	-0.8	13.6	0.70	100
0.97	7.50	7.63	-0.13	-1.7	11.7	0.64	100
0.97	7.47	7.57	-0.10	-1.3	11.7	0.64	100
0.75	4.99	5.12	-0.13	-2.6	9.1	0.55	100
Mean -1.1							
Width of approach channel, 10.0 feet							
2.66	36.20	36.45	-0.25	-0.7	29.4	1.23	111
2.36	30.33	30.28	+0.05	-0.2	25.9	1.17	112
2.05	24.51	24.34	+0.17	+0.7	22.6	1.08	111
1.68	17.93	17.80	+0.13	+0.7	18.5	0.97	111
1.23	11.11	11.03	+0.08	+0.7	13.5	0.82	112
1.08	8.89	8.94	-0.05	-0.6	11.7	0.76	112
0.75	4.99	5.12	-0.13	-2.6	8.1	0.62	113
Mean -0.3							
Width of approach channel, 8.0 feet							
2.56	34.28	34.34	-0.06	-0.2	22.7	1.51	139
2.31	29.13	29.25	-0.12	-0.4	20.4	1.43	139
1.97	23.05	22.88	+0.17	+0.7	17.4	1.33	139
1.50	15.05	14.92	+0.13	+0.9	13.2	1.14	138
1.16	9.98	10.07	-0.09	-0.9	10.1	0.99	139
0.98	7.68	7.75	-0.07	-0.9	8.6	0.89	138
0.75	4.97	5.07	-0.10	-2.0	6.6	0.75	136
Mean -0.4							
Width of approach channel, 6.0 feet							
2.39	30.76	30.89	-0.13	-0.4	15.9	1.93	184
2.19	27.01	26.96	+0.05	+0.2	14.6	1.85	184
2.02	23.89	23.79	+0.10	+0.4	13.3	1.80	187
1.71	18.41	18.38	+0.03	+0.2	11.3	1.63	184
1.38	13.16	13.10	+0.06	+0.5	9.1	1.45	185
1.05	8.52	8.63	-0.11	-1.3	6.8	1.25	185
0.75	4.97	5.12	-0.15	-3.0	4.9	1.02	186
Mean -0.5							
Width of approach channel, 3.96 feet (Bellvue laboratory, 1932)*							
1.50	15.01	15.00	+0.01	+0.1	6.14	2.44	296
1.00	7.95	8.00	-0.05	-0.6	4.08	1.95	295
0.55	3.01	3.17	-0.16	-5.3	2.22	1.36	293
Mean -1.9							

*For the 1932 observations the depth of water in channel of approach was computed by Bernouilli's theorem.

TABLE X.—COMPARISON OF LOSS OF HEAD IN FEET FOR VARIOUS DISCHARGES THROUGH THE PARSHALL MEASURING FLUME AND THE SAME DISCHARGE OVER WEIRS

Discharge	Parshall measuring flume				Standard rectangular weir				Standard cipoletti weir				90-degree triangular notch weir
	6-inch	1-foot	2-foot	4-foot	6-inch	1-foot	2-foot	4-foot	6-inch	1-foot	2-foot	4-foot	
Sec.-ft.	Feet	Feet	Feet	Feet	Feet	Feet	Feet	Feet	Feet	Feet	Feet	Feet	Feet
0.10	0.06	0.15	0.15	0.27
0.50	0.15	0.08	0.46	0.29	0.18	0.43	0.28	0.18	0.52
1.00	0.33	0.14	0.09	0.74	0.46	0.29	0.18	0.64	0.44	0.28	0.18	0.69
2.00	0.56	0.21	0.14	0.09	1.16	0.75	0.46	0.29	0.96	0.69	0.45	0.28	0.92
3.00	0.28	0.18	0.12	0.99	0.61	0.38	0.88	0.58	0.37	1.08
5.00	0.38	0.25	0.16	0.86	0.53	0.82	0.52	1.32
7.50	0.50	0.32	0.21	1.13	0.70	1.06	0.68
10.00	0.60	0.40	0.25	0.85	1.27	0.83
12.50	0.68	0.45	0.28	0.99	0.96
15.00	0.52	0.32	1.12	1.08
20.00	0.62	0.40	1.36	1.31

limitations of bottom and side distances, the velocity of approach should be about $\frac{1}{3}$ foot per second, and the error from this source about 1 percent of the discharge. To take the extreme case where the bottom and side distance are each $\frac{1}{2}$ foot for a 1-foot rectangular weir with a head of 0.6 foot, the error in discharge due to the velocity of approach is found to be 4.6 percent. For these same distances and head, but with a 4-foot rectangular weir, the error in discharge is 10.5 percent. For a 1-foot and a 4-foot weir, with 1-foot head and the bottom and side distances each at 1 foot, the error in discharge is 2.8 percent and 6.8 percent, respectively. As the head increases, the error also increases, assuming that the bottom and side distances remain fixed. For this fixed condition the error increases as the length of crest is increased.

COMPARISON OF LOSS OF HEAD FOR VARIOUS DISCHARGES OVER STANDARD WEIRS AND THROUGH THE PARSHALL MEASURING FLUME

Table X has been prepared to show the relative loss of head in feet for various discharges through the flume and over weirs. For the 6-inch flume the degree of submergence at 50 percent was taken as the limit of free flow, while for the 1-, 2-, and 4-foot flumes the limiting percentage was taken at 70. It is to be noted in this comparison that the values given under the headings for the various weirs represent the actual head on the crest to give the corresponding discharge. The loss of head is, in reality, greater than that indicated by the distance between the water surface downstream from the weir and the crest. This additional fall is necessary to permit the free passage of air underneath the nappe, or overpouring stream of water, and may be assumed to be from 0.05 to 0.10 foot.

ACCESSORIES

For small flows through the Parshall measuring flume, a staff gage set flush with the inside face of the converging section at the proper distance back from the crest may be found satisfactory to determine the upper head, H_a , for free flow. For higher heads it has been found inadvisable to use the staff gage placed on the inside face of the flume. If the flow is submerged, the throat gage on the inside face will be found unsatisfactory because of the roughness of the water surface. As the degree of submergence increases, the water becomes less disturbed; but for high submergence the error in reading the head may cause a large error in the computed discharge, even though the reading may be carefully observed. It is thought, however, that more satisfactory results will be obtained by placing the staff gages, or scales, in the stilling wells as suggested in figure 1.

For important installations of the Parshall measuring flume where permanent records of the flow are desired, there has been designed a

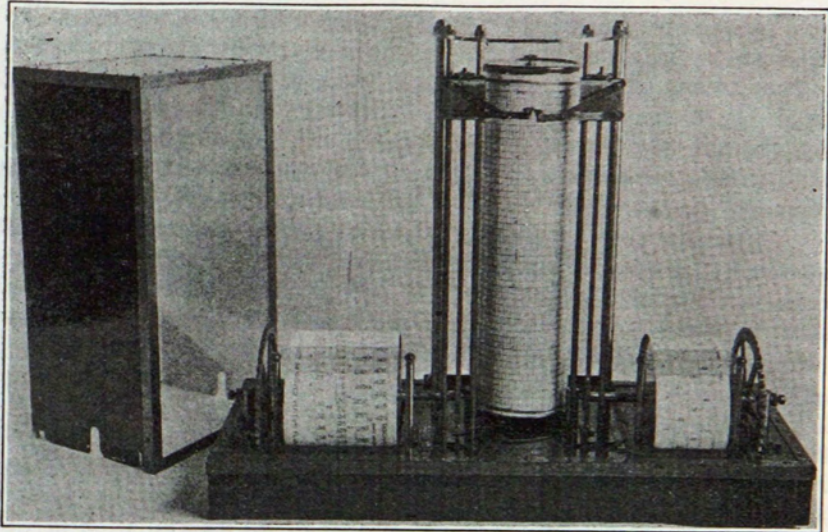

Figure 28.—Double-head recording and indicating instrument designed for use in connection with the Parshall measuring flume.

special double-head indicating and recording instrument for use in connection with this type of measuring device. Field use has proved this recorder to be of practical design and well suited to the purpose.

This instrument, figure 28, has a base of 8 by 21.5 inches and is 17.5 inches high, equipped with a vertical clock cylinder which turns one revolution in 7.5 days, and carries an especially-designed, convenient chart. The recording gage-height range is 5 feet. The clock used is a high-grade movement, arranged so that a friction gear permits the chart to be set to the correct time by merely turning the cylinder in place as desired. On two independent rotating shafts, suitably mounted on the base of the instrument, drums are fixed which indicate the H_a and H_b gage heights. Each of these is moved by a sprocket wheel and chain, the latter being attached to a float in the well, and the system is balanced by a counterweight. The H_a and H_b gage heights are read on continuous spiraled scales, graduated in feet, on the surface of the drums. The scales are of neat, clear-cut marking, printed on white pyralin strips which are afterward formed into cylinders of the proper diameter and provided with heavy pyralin heads, securely fixed to the sprocket wheel shaft. Mounted on brass supports is a strip of clear pyralin with a fine, black-etched line spanning the face of each cylinder. Any change or variation of the water surface in the wells is indicated by the movement of the scale beneath this index line. The drum at the right gives the value of the H_b head in feet, and at the left is a wider-faced drum bearing two sets of graduations, one set giving the H_a readings in feet and the other showing in

bold-faced type the rate of free-flow discharge in second-feet. The H_a drum with its discharge graduations is especially designed for any particular size of flume. These instruments are designated as "right hand" or "left hand", according to whether the H_a drum is at the right or left when facing the instrument. This arrangement is necessary as a convenience to operation, depending on whether the stilling wells are located on the right- or left-hand side of the flume.

Each pen used to scribe the graphs on the graduated chart is mounted on a suitable headblock carried at the upper end of a vertical rack, meshing with a small gear of proper diameter attached to the shaft carrying the sprocket wheel and indicating drum.

Parallel guiderods direct the pens vertically along the hour-line of the chart. Each pen is synchronized to the drum reading for gage height, and since the index line crosses more than one line of graduations, it is only necessary to read approximately the indicated chart reading and then observe to close limits the actual value of the head as shown on the drum.

In the operation of this instrument, the only manipulation necessary is to remove the cylinder, wind the clock, and change the chart. To remove the cylinder, the H_a and H_b pens are lifted from the chart by a suitable lever arrangement, and the cylinder is then lifted vertically from its pivot support. The key for winding is attached to the clock movement and extends to the top of the cylinder. An ornamental cover fits snugly over the top as a protection. The blank chart, cut to fit, is laid around the cylinder and rests against a ring projection at the bottom. Rubber bands are used to hold the sheet in place. Paste may be used to seal the edges if desired.

The distance between sprocket wheels is 18 inches, and where 12-inch floats are used only 6 inches are available to clear the vertical diaphragm in the float wells. If a concrete partition wall is used to separate the H_a and H_b compartments, it is found that with a practical thickness of wall there is not sufficient safe margin or clearance for the travel of the floats. A metal diaphragm, with horizontal angle-iron stiffeners, occupying only about 2.5 inches, is more suitable for separating the compartments.

To locate properly the position of the instrument on the cabinet, it is necessary to plumb carefully from the diaphragm up to the under side of the top of the cabinet, and there drive through a nail. From the point thus obtained on the top, the places for the holes for the sprocket chains and those through which the penracks are to pass may be marked. To provide ample clearance, 1-inch auger holes are recommended. The instrument base is now shifted to position and firmly fixed by screws at the ends. The sprocket chains are threaded through, and the float and counterweight are attached. The mounting and setting of the instrument require no special expert mechanical skill.

By carefully determining the mean crest elevation, using an engineer's level and rod, a reference point or bench mark is set over each well. The elevation of these marks above the mean elevation of the crest is calculated to 0.001 foot and posted at each point. A special weighted hookgage attached to a lightweight steel tape, graduated to 0.01 foot, is used to determine the vertical distance between the water surface and the fixed reference point. To use the hookgage plumb bob, attach it to the ring of the steel tape and lower it into the water in the well until the point is submerged. Carefully raise until the point just appears, and then read the tape at the reference point. This tape reading will, of course, be the distance to the zero point of the tape. To this must be added the distance from the point of the hook to the zero point of the tape. The sum is the distance from the reference point to the water surface, and this sum subtracted from the elevation of the reference point will be the actual effective head. The drum reading on the instrument is observed at the same time that the hookgage reading is taken, the resulting difference indicating the error in the instrument reading.

In setting the instrument for the first time, a material error may be expected. By moving the chain on the sprocket, large corrections may be made until a fair agreement is attained. Several hookgage and drum readings should next be taken simultaneously. The difference between the means of these observations will indicate the extent

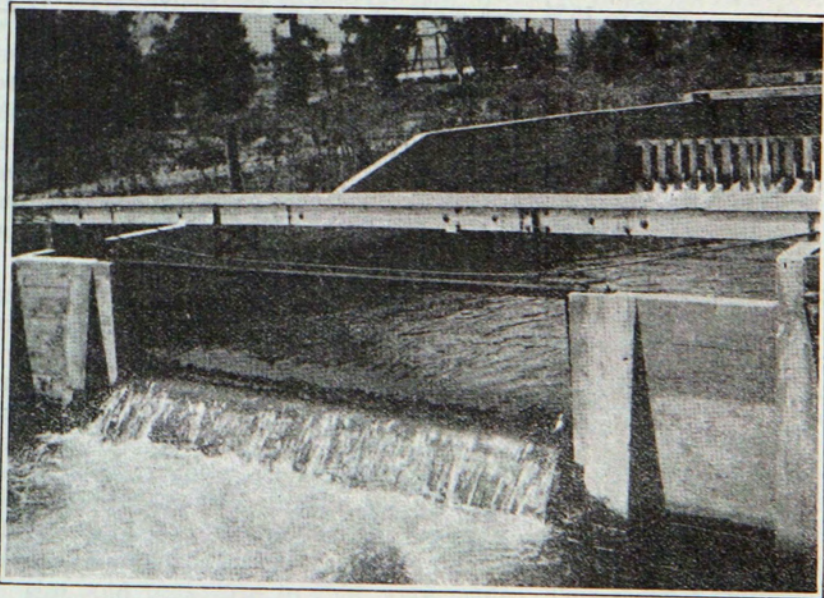

Figure 29.—Fifteen-foot standard rectangular weir at the Bellvue hydraulic laboratory. Discharge 40 second-feet. Actual length of crest, 14.98 feet

of the correction which must be made by adjusting the lock-nut attachment at the float. The comparison of both drums and final adjustments must be made before actual discharge calculations are possible.¹⁰

GENERAL COMMENT AND NOTES CONCERNING ORIGINAL DATA

The original data given in tables XI to XXIX constitute the results of the complete series of both free-flow and submerged-flow tests used in the determination of the discharge formulas for these two conditions.

Tests 6295 to 6494 were made in 1923 at the Bellvue laboratory, where a standard 10-foot rectangular weir was used to determine the observed discharge through the various sizes of experimental Parshall measuring flumes. For the smaller discharges, experimental flumes of 1-, 2-, and 3-foot sizes were tested at the Fort Collins hydraulic laboratory as indicated in the tables which follow.

Tests 7015 to 7138 were made in the fall of 1924 at the Bellvue laboratory, where the 10-foot standard rectangular weir was used to obtain the observed discharge. Only a limited number of this series of tests was used in the comparison because they were purposely run at high submergence and H_a depths greater than 2.5 feet. The few tests considered were made a part of the 1923 series, as they were used in the original derivation of the discharge formulas.

Tests 7285 to 7554 were made in 1926 at the Bellvue laboratory, where a standard 15-foot rectangular weir was used to determine the observed discharge, figure 29. Tests 7555 to 7615 were also made at the Bellvue laboratory, but apply to a different device. A standard 4-foot rectangular weir was used in tests 7616 to 7712, figure 30, while for tests 7713 to 7756 an 18-inch rectangular weir was used. Tests 7757 to 7773 were made where the 15-foot weir was used to determine the discharge. It will be found for tests on the 2-foot flume that four different-sized weirs, as well as volumetric determinations of discharge, were used in the calibration.

The computed discharges for tests 7674 to 7683, 1-foot flume, were reduced by 2 percent because the dimension of width of throat was incorrect.

Tests 7379 to 7388 were made on the 8-foot Parshall measuring flume as special observations to determine the effect of increasing the length of the converging section of the structure. In this case the length of side was increased from the standard dimension of 8 feet to 14.5 feet. This increase of length of side gave a width of structure at the front end of 14.0 feet. It will be noted that the computed discharges for both the free flow and submerged flow agree quite closely

¹⁰Further information concerning the double-head indicating instrument may be obtained by addressing the Colorado Experiment Station, Fort Collins.

with the observed discharge. The hydraulic condition of flow within or through this setting was very good. See table XXIX.

The series of tests at the Bellvue laboratory in 1923 was for the most part made with duplicate readings of the upper head, H_a , on the experimental flumes; that is, the head was determined at corresponding points on opposite sides of the converging section and the value of the mean used as the effective head. The throat head, H_b , was a single determination. The 1926 series of tests at the Bellvue laboratory was made with duplicate readings of both H_a and H_b , and the means determined as the effective heads. It was found that the upper head, H_a , as observed on either side of the flume, gave very consistent agreement, while the two throat gages gave results that were more discordant. Examination of the mean values of H_b shows that for the 8-foot flume these differ as a maximum as much as 0.07 foot for a discharge of 80 second-feet, and for submergence between 50 and 80 percent. These maximum differences in the H_b mean readings indicate that one gage was consistently high, but in general it was found that either one may be greater. As the size of flume decreases the maximum difference in the throat gages also decreases, but the tendency is for greater differences to show for the lower degree of submergence. These inconsistencies under laboratory settings would warrant the conclusion that for field conditions, where only approximate methods are used to determine the heads, an accurate determination of the computed submerged-flow discharge would not be expected. However, it is believed on the whole that submerged-flow measurements in the field are possible, allowing for these apparent inconsistencies of the throat-gage reading.

The first nine tests, free flow, on the 8-foot flume, series of 1926, showed a difference of 0.03 to 0.05 foot in the H_a gages. Examination of the floor disclosed an irregularity near the gage opening at one side. The removal of this obstruction appeared to correct the difficulty, and thereafter very close agreement with the opposite, H_a , reading was obtained. Elevations taken on the crest of this 8-foot flume at the beginning showed one end to be approximately 0.03 foot low. Commencing with test 7310, the floor in the converging section had been removed and the crest adjusted to within about 0.005 foot. Free-flow discharge for succeeding tests showed better agreement. The general trend of all tests on this 8-foot setting was for the observed discharge, as determined by the 15-foot standard rectangular weir, to be in excess of the computed discharge. The mean width of throat at the conclusion of test 7388 was 7.98 feet. Computed discharges for this 8-foot setting were corrected accordingly. After completing the tests on the 4-foot flume the apparatus was again adjusted to an 8-foot size, and tests 7518 to 7554 were made. This short series shows a better agreement between the computed and observed discharges.

Tests on the 6-foot flume, 7389 to 7455, series of 1926, show fair agreement. These tests were made by four different observers. For discharges of 75 to 85 second-feet, free flow, the contraction effect caused by the water flowing past the upstream end of the converging section resulted in a pronounced dip or depression at the point vertically above the piezometer opening to H_a gage stilling wells. This depression was estimated to be about 3 inches below the general slope of the inclined water surface. The law of the discharge is based upon stilling-well depths, and the fact that the static head is reduced by the contraction does not vitiate the results of this seemingly erratic condition. Gage staffs or scales placed on the inside face of the converging section to permit the head, H_a , to be read would be unsatisfactory for large free-flow discharges.

For the 4-foot setting, test 7501, the discharge was free flow; that is, unrestricted by back water, similar to that shown in figure 3. This test showed a gage ratio of approximately 74 percent, and even though strictly free flow, it was classified as a submerged test and corrected accordingly. At this discharge the throat was filled to such an extent that the gage at this point registered a depth of more than the free-flow limit. Had this test been considered as free flow, the deviation between the observed and computed discharges would have been approximately 1.1 percent.

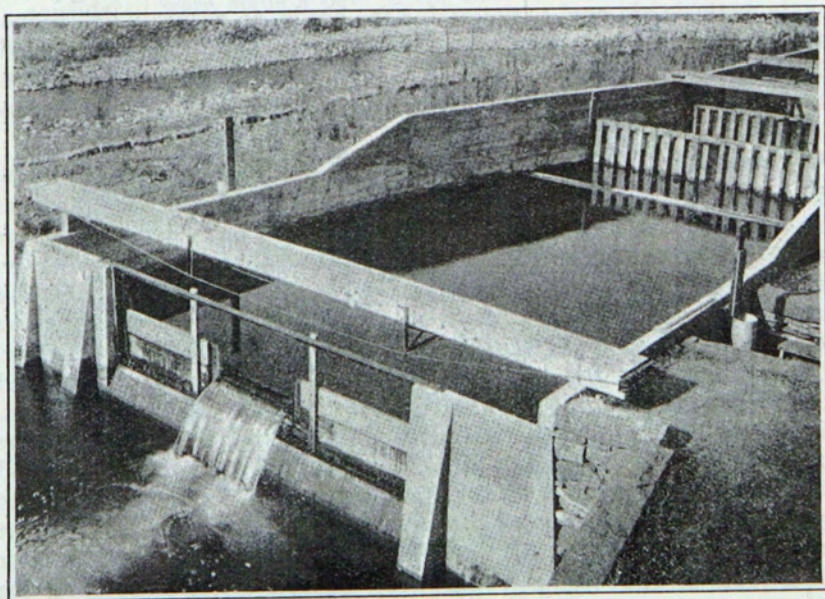

Figure 30.—Weir basin at the Bellvue hydraulic laboratory, with a 4-foot rectangular weir mounted on the 15-foot crest. Weir heads determined by two hookgages as shown. Discharge over the 4-foot weir, 7.67 second-feet.

The flume will withstand a high degree of submergence without affecting the rate of free-flow discharge, and for this reason it is recommended that the H_b stilling well be provided to obtain the full efficiency of the flume.

Because of the increased velocity of the water, it will operate successfully in sand- or silt-laden streams. Since the floor of the structure is constantly swept clean of all deposit, constancy of condition is maintained.

Operation is simple because it has no adjustable or moving parts.

Its dimensions are not easily altered so as to cause wilfully unfair measurement of the discharge. The filling of the weir box upstream from the crest, by natural deposit from the stream, causes the weir to over-register, and consequently there is no incentive on the part of the water user to correct this condition. Discharge through rating flumes may be changed to the advantage of the user by altering downstream conditions.

Velocity of approach of the stream to the entrance of this device has little or no effect upon the rate of discharge.

Plane surfaces in the structure make it easy to construct. For moderately large flows the upper ends of the converging section should be rounded off by means of sheet metal pieces rolled to a radius of 4 or 5 feet.

The structure may be built of wood, concrete, or sheet metal. Precast concrete members may be made and assembled in the field for the small-sized flumes. Sheet metal flumes, portable because of their light weight, are entirely practical for the small sizes.

Recording instruments may be operated in connection with this device to register heads or total discharge.

Where the degree of submergence exceeds about 95 percent, the indicated discharge through the flume is not wholly dependable. If conditions permit, the discharge should be free flow or with the least possible degree of submergence.

For free flow, the flume's measurement of discharge depends upon a single head or depth only, it being similar in this respect to a standard weir or rating flume.

The upper head in the converging section, or the throat head, may be read on either side of the flume with equal accuracy.

Scales or gages attached to the inside of the flume for the purpose of determining the head are not recommended except for small flows or moderate depth and free-flow condition. Better results are obtained if the heads are observed in stilling wells outside the structure.

For free flow the exit velocity is relatively high, and bottom as well as bank protection must be provided to prevent erosion. Where

the materials are of such a nature as to withstand a high velocity, such as heavy gravel or rock, no attention need be given to protection.

The Parshall measuring flume has the advantage over the old type of Venturi flume in that the angles of convergence and divergence are such as to eliminate the effect of the switching of the current in the diverging section, which, in the old flume, affected the discharge. The elimination of this effect made possible the determination of the discharge by means of single, upper, and throat heads; in the old flume it was recommended that these heads be observed on both sides and the mean reading used as the basis of computing discharge. The dip in the floor at the throat section permits the formation of a hydraulic jump downstream from the throat section, thus leaving the conditions of flow in the converging section unaffected by submergence until the degree of the submerged flow reaches 70 percent, or where the ratio of the upper head, H_a , and throat head, H_b , both referred to the crest as the datum, has a value of 0.7.

ACKNOWLEDGMENT

The author wishes to acknowledge the assistance and cooperation of the Jackson Ditch Company of Laporte, Colo., in permitting the use of its diversion dam and headworks in connection with the operation of the irrigation hydraulic laboratory at Bellvue. To those who have made valuable suggestions and criticisms, he wishes to extend his most sincere thanks.

BIBLIOGRAPHY

- CONE, V. M.—1917. *Journal of Agricultural Research*, Vol. IX, No. 4.
- REIGEL, R. M., and BEBEE, J. C.—1917. *The Hydraulic Jump as a Means of Dissipating Energy*. Technical Report. Part III. Miami Conservatory District. Dayton, Ohio.
- LANE, E. W.—1919. *Experiments on the Flow of Water Through Contractions in an Open Channel*. *Trans. American Society of Civil Engineers*. Vol. LXXXIII.
- WILSON, P. S., and WRIGHT, C. A.—1920. *A Study of the Venturi Flume as Measuring Device in Open Channels*. *Engineering News-Record*. Vol. 85. No. 10.
- HINDS, JULIAN.—1920. *Venturi Flume Data Throw Light upon "Control Weir"*. *Engineering News-Record*. Vol. 85. No. 26.
- PARSHALL, R. L., and ROHWER, CARL—1921. *The Venturi Flume*. *Colorado Experiment Station Bulletin* 265.
- WALKER, W. J.—1922. *Anomalous Results in Venturi Flume and Meter Tests*. *Engineering News-Record*. Vol. 88. No. 10.
- CRUMP, E. S.—1922. *Moduling of Irrigation Channels*. Punjab Irrigation Branch. Paper No. 26.
- SAVAGE, J. L.—1924. *Discharge Measurements for the Control Section Weir*. *Engineering News-Record*. Vol. 92. No. 20.
- LEDoux, J. W.—1924. *Open End Flume Water Meter Based on Exponential Equation*. *Engineering News-Record*. Vol. 93. No. 13.
- PARSHALL, R. L.—1925. *The Improved Venturi Flume*. *Colorado Experiment Station Press Bulletin* 60.
- PARSHALL, R. L.—1926. *The Improved Venturi Flume*. *Transactions, American Society of Civil Engineers*. Vol. 89.
- PARSHALL, R. L.—1932. *Measuring Water in Irrigation Channels*. U. S. D. A. *Farmer's Bulletin* 1683.
- PARSHALL, R. L.—1932. *Parshall Flumes of Large Size*. *Colorado Experiment Station Bulletin* 386.
- ENGEL, F. V. A. E.—1934. *The Venturi Flume*. *The Engineer*, August 3rd and 10th.

Profiles of the water surfaces were taken along the longitudinal axis of the flume for tests 7511-7517. It was found for these tests that the gage, H_a , agreed reasonably well with measured depth in the flume; however, in all cases the stilling well exceeded the profile in amounts ranging from 0.01 to 0.03 foot. Greater variation was found to exist in the H_b hookgage readings.

Nothing of unusual importance was observed in connection with these tests on the 2-foot flume. Test 7763, free-flow discharge, gave the maximum flow through this size structure in 1926, this test being limited to the total supply available in the river. At the Bellvue laboratory in 1923, a test was made on the 2-foot flume where the upper head, H_a , was 2.65 feet and the gage ratio 72 percent. This condition of flow was similar to test 7501 for the 4-foot flume. Assuming the condition as free flow, it was found that the deviation of computed and observed discharge was approximately 1.1 percent, the computed discharge being in excess for both these maximum flows.

It was found in testing the 1-foot flume that the computed discharges for tests 7674 to 7683 had to be reduced by 2 percent, due to reduction in mean length of crest.

Ice was a troublesome factor at the Bellvue laboratory in 1926, during the time tests were being made on the 1-foot and 2-foot flumes. It is believed, however, that it had little or no effect upon the accuracy of the work.

The calibration of the 3- and 9-inch flumes was made under laboratory settings. In both cases the experimental flumes were made of galvanized sheet metal and carefully dimensioned.

SUMMARY

The Parshall measuring flume has shown in field operation that it is practical under conditions which make a standard weir or rating flume impractical, either because of silting trouble or insufficient grade.

The accuracy of measurement with this device is entirely within practical limits. The observed discharge, free flow, was within 3 percent of the computed amount in 89 percent of the tests. For the submerged flow, 85 percent of the observed discharges were within 5 percent of the computed amounts.

The range of capacity of discharge from a minimum of less than 0.10 second-foot through the 3-inch flume to a maximum of 1,500 second-feet through the 40-foot flume, as limited by present investigations, is sufficient to meet ordinary requirements.

This device operates successfully with relatively small loss of head, and for free flow this loss in a standard weir is approximately four times that in the flume.

TABLE XI.—ORIGINAL FREE-FLOW DATA FOR 3-INCH PARSHALL MEASURING FLUME, 1930

Test	Flume heads		Ratio H _b /H _a	Head on weir	Discharge		Difference	Deviation
	H _a	H _b			Obs.	Comp.		
	Feet	Feet			Sec.-ft.	Sec.-ft.	Sec.-ft.	Percent
8201	1.110	0.667	0.601	V.M.*	1.181	1.166	-0.015	1.3
8211	1.049	.633	.603	V.M.	1.070	1.068	-.002	0.2
8212	1.048	.634	.604	V.M.	1.068	1.067	-.001	0.1
8173	.988	.591	.598	V.M.	.974	.974	.000	0.0
8213	.951	.577	.607	V.M.	.914	.918	+ .004	0.4
8210	.949	.573	.604	V.M.	.912	.915	+ .003	0.3
8174	.897	.539	.601	V.M.	.840	.838	-.002	0.2
8209	.849	.511	.603	V.M.	.764	.770	+ .006	0.8
8175	.797	.475	.596	V.M.	.697	.698	+ .001	0.1
8208	.748	.447	.598	V.M.	.624	.633	+ .009	1.4
8187	.704	.417	.592	V.M.	.574	.576	+ .002	0.4
8176	.700	.408	.583	V.M.	.568	.571	+ .003	0.5
8207	.651	.379	.582	V.M.	.512	.510	-.002	0.4
8177	.600	.335	.558	V.M.	.447	.450	+ .003	0.7
8206	.550	.302	.549	V.M.	.390	.393	+ .003	0.8
8178	.500	.255	.510	V.M.	.341	.339	-.002	0.6
8205	.451	.220	.488	V.M.	.290	.290	.000	0.0
8179	.400	.170	.425	V.M.	.244	.241	-.003	1.2
8191	.399	.252	.632	V.M.	.237	.240	+ .003	1.3
8204	.350	.133	.380	V.M.	.197	.196	-.001	0.5
8180	.300	.076	.253	V.M.	.156	.154	-.002	1.3
8203	.249	.035	.141	V.M.	.116	.116	.000	0.0
8181	.201	-.025	V.M.	.083	.083	.000	0.0
8202	.160	V.M.	.058	.058	.000	0.0
8182	.100	V.M.	.028	.028	.000	0.0

*Volumetric measurements, Hydraulic Laboratory, Fort Collins.

TABLE XII.—ORIGINAL FREE-FLOW DISCHARGE DATA FOR 6-INCH PARSHALL MEASURING FLUME, 1926

Test	Flume heads		Ratio H _b /H _a	Head on weir	Discharge		Difference	Deviation
	H _a	H _b			Obs.	Comp.		
	Feet	Feet			Sec.-ft.	Sec.-ft.	Sec.-ft.	Percent
7214	0.215	0.352	0.186	0.182	-0.004	2.2
7215	.398517	.433	.481	-.002	0.4
7216	.612	0.095	0.155	.678	.947	.948	+ .001	0.1
7217	.825	.284	.344	.815	1.500	1.520	+ .020	1.3
7218	.971	.404	.416	.908	1.960	1.966	+ .006	0.3
7219	.123244	.075	.075	.000	0.0
7220	.204338	.163	.167	-.001	0.6
7221	.303436	.316	.312	-.004	1.3
7222	.391513	.475	.467	-.008	1.7
7223	.520	.012	.023	.615	.745	.733	-.012	1.6
7224	.595	.077	.129	.669	.917	.907	-.010	1.1
7225	.708	.178	.251	.745	1.200	1.194	-.006	0.5
7226	.909	.348	.383	.870	1.760	1.772	+ .012	0.7
7227	.716	.194	.271	.750	1.220	1.215	-.005	0.4
7228	.809	.275	.340	.810	1.480	1.474	-.006	0.4
7229	1.011	.441	.436	.936	2.110	2.096	-.014	0.7
7230	1.116	.524	.470	.988	2.420	2.450	+ .030	1.2
7231	.137260	.088	.089	+ .001	1.1
7232	.093208	.051	.048	-.003	5.9
7233	.509	.139	.273	.608	.723	.709	-.014	1.9
7250	.320	.146	.457	.453	.34	.34	.00	0.0
7259	.217	.103	.475	.352	.18	.19	+ .01	5.6
7276	.997	.493	.495	.925	2.01	2.00	-.01	0.5

TABLE XIII.—ORIGINAL FREE-FLOW DATA FOR 9-INCH PARSHALL MEASURING FLUME, 1930

Test	Flume heads		Ratio H_b/H_a	Head on weir	Discharge		Difference	Deviation
	H_a	H_b			Obs.	Comp.		
	Feet	Feet		Feet	Sec.-ft.	Sec.-ft.	Sec.-ft.	Percent
7999	0.113	V.M.	0.109	0.109	.000	0.0
8000	.210	V.M.	.278	.282	+ .004	1.4
8001	.310	V.M.	.501	.513	+ .012	2.4
8002	.494	V.M.	1.041	1.043	+ .002	0.2
8003	.717	V.M.	1.881	1.845	— .036	1.9
8004	.922	V.M.	2.763	2.711	— .052	1.9
8005	1.120	V.M.	3.696	3.651	— .045	1.2
8006	1.228	V.M.	4.260	4.204	— .056	1.3
8007	.443	V.M.	.884	.884	— .000	0.0
8008	.573	V.M.	1.320	1.310	— .010	0.8
8009	.744	V.M.	1.982	1.952	— .030	1.5
8491	.347	0.199	.596	.608	+ .012	2.0
8492	.546324	1.234	1.215	— .019	1.5
8493	.727435	1.920	1.885	— .035	1.8
8494	.878525	2.550	2.517	— .033	1.3
8495	1.002600	3.130	3.080	— .050	1.6
8496	1.153695	3.910	3.815	— .095	2.4
8497	1.287	0.613	0.477	.773	4.607	4.517	— .090	2.0
8498	.374217	.675	.682	+ .007	1.0
8499	.219122	.296	.301	+ .005	1.7
8525	.853	.486	.570	.505	2.405	2.407	+ .002	0.1
8530	.836	.465	.556	.494	2.328	2.333	+ .005	0.2
8532	.540316	1.186	1.194	+ .008	0.7

TABLE XIV.—ORIGINAL FREE-FLOW DISCHARGE DATA FOR 1-FOOT PARSHALL MEASURING FLUME, 1923

Test	Flume heads		Ratio H _b /H _a	Head on weir	Discharge		Difference	Deviation
	H _a	H _b			Obs.	Comp.		
	Feet	Feet		Feet	Sec.-ft.	Sec.-ft.	Sec.-ft.	Percent
6478	2.516	1.615	0.642	0.623	16.13	16.29	+0.16	1.0
6479	2.404	1.512	.629	.595	15.09	15.20	+ .11	0.7
6480	2.420	1.543	.638	.594	15.05	15.35	+ .30	2.0
6481	2.419	1.578	.653	.595	15.09	15.34	+ .25	1.7
6484	2.132	1.268	.595	.528	12.66	12.66	— .00	0.0
6485	1.828	.976	.534	.453	10.05	10.02	— .03	0.3
6486	1.168	.251	.215	.284	5.04	5.07	+ .03	0.6
6487	1.516	.662	.436	.373	7.53	7.54	+ .01	0.1
6491	1.852	1.160	.626	.450	9.95	10.22	+ .27	2.7
6647	1.302	.491	.377	V.M.*	6.04	5.97	— .07	1.2
6648	1.199	.376	.314	V.M.	5.32	5.27	— .05	0.9
6649	.500	— .193	V.M.	1.37	1.39	+ .02	1.5
6650	1.099	.262	.238	V.M.	4.65	4.61	— .04	0.9
6651	1.000	.147	.147	V.M.	4.01	4.00	— .01	0.2
6652	.899	.029	.032	V.M.	3.39	3.40	+ .01	0.3
6653	.402	— .155	V.M.	.96	1.00	+ .04	4.2
6654	.301	— .133	V.M.	.62	.64	+ .02	3.2
6655	.201	— .143	V.M.	.33	.35	+ .02	6.0
6659	1.802	1.011	.562	V.M.	9.82	9.81	— .01	0.1
6660	1.699	.910	.536	V.M.	8.94	8.96	+ .02	0.2
6661	1.603	.813	.507	V.M.	8.20	8.20	— .00	0.0
6662	1.501	.709	.472	V.M.	7.45	7.42	— .03	0.4
6663	1.399	.599	.428	V.M.	6.69	6.67	— .02	0.3
6664	.801	— .086	V.M.	2.84	2.85	+ .01	0.4
6665	.701	— .200	V.M.	2.30	2.33	+ .03	1.3
6666	.601	— .308	V.M.	1.83	1.84	+ .01	0.5
6703	.398	.276	.694	V.M.	.91	.98	+ .07	7.7

Check Tests, Bellvue Laboratory, 1926

7662	1.182	0.549	5.26	5.16	—0.10	1.9
7667	1.189	0.724	0.609	.540	5.13	5.20	+ .07	1.4
7668	1.881883	10.59	10.47	— .12	1.1
7672	.619273	1.88	1.92	+ .04	2.1
7674	.294120	.57	.62	+ .05	8.8
7679	.289	.144	.498	.118	.55	.61	+ .06	10.9
7680	.499213	1.31	1.39	+ .08	6.1
7684	.273111	.51	.55	+ .04	7.8
7689	.584255	1.70	1.77	+ .07	4.1
7692	1.187545	5.20	5.19	— .01	0.2
7695	2.451	1.167	15.96	15.65	— .31	1.9
7699	2.150	1.009	12.89	12.82	— .07	0.5
7703	1.563731	8.02	7.89	— .13	1.6
7704	1.592	1.082	.679	.726	7.94	8.12	+ .18	2.3
7708	.950428	3.64	3.70	+ .06	1.6
7712	.392165	.91	.96	+ .05	5.5
7713	.683602	2.21	2.24	+ .03	1.4
7714	.519455	1.47	1.48	+ .01	0.7
7715	.409349	.99	1.03	+ .04	4.0
7716	.332284	.74	.75	+ .01	1.4
7717	.275226	.53	.56	+ .03	5.7
7718	.278228	.53	.57	+ .04	7.5
7725	.585	.332	.568	.506	1.71	1.77	+ .06	3.5
7730	.315262	.65	.69	+ .04	6.2
7731	.476407	1.25	1.29	+ .04	3.2
7732	.605526	1.82	1.86	+ .04	2.2
7733	.739653	2.49	2.52	+ .03	1.2
7734	.588510	1.73	1.79	+ .06	3.5
7735	.335285	.74	.75	+ .01	1.4

*Volumetric measurements, Hydraulic Laboratory, Fort Collins.

TABLE XV.—ORIGINAL FREE-FLOW DISCHARGE DATA FOR 2-FOOT PARSHALL MEASURING FLUME, 1923

Test	Flume heads		Ratio H _b /H _a	Head on weir	Discharge		Difference	Deviation
	H _a	H _b			Obs.	Comp.		
	Feet	Feet		Feet	Sec.-ft.	Sec.-ft.	Sec.-ft.	Percent
6435	2.350	1.640	0.698	0.943	29.94	30.08	+0.14	0.5
6438	2.094	1.368	.653	.836	25.03	25.16	+ .13	0.5
6443	1.794	1.048	.584	.717	19.90	19.79	— .11	0.6
6444	1.505	.719	.478	.596	15.12	15.08	— .04	0.3
6448	1.129	.256	.227	.439	9.59	9.66	+ .07	0.7
6449	.965	.042	.044	.371	7.47	7.57	+ .10	1.3
6450	.973	.239	.246	.372	7.50	7.67	+ .17	2.3
6453	.752	— .244282	4.99	5.14	+ .15	3.0
6587	1.000	.147	.147*	V.M.*	8.10	8.00	— .10	1.2
6588	.901	.018	.020	V.M.	6.83	6.81	— .02	0.3
6589	.799	— .109	V.M.	5.65	5.65	.00	0.0
6590	.701	— .234	V.M.	4.59	4.61	+ .02	0.4
6591	.601	— .157	V.M.	3.59	3.63	+ .04	1.1
6592	.500	— .112	V.M.	2.69	2.73	+ .04	1.5
6593	.399	— .106	V.M.	1.89	1.92	+ .03	1.6
6594	.301	— .107	V.M.	1.22	1.25	+ .03	2.5
6595	.202	— .127	V.M.	.65	.67	+ .02	3.1
6596	1.101	.274	.249	V.M.	9.40	9.28	— .12	1.3
6597	1.200	.401	.334	V.M.	10.76	10.61	— .15	1.4
6598	1.587	.858	.540	V.M.	16.63	16.37	— .26	1.6
6599	1.501	.762	.508	V.M.	15.16	15.02	— .14	0.9
6600	1.303	.523	.401	V.M.	12.19	12.06	— .13	1.1
6601	1.400	.644	.460	V.M.	13.73	13.48	— .25	1.8
6605	1.606	.872	.543	V.M.	16.73	16.68	— .05	0.3
6611	1.604	.480	.299	V.M.	16.89	16.64	— .25	1.5
6636	.399	.223	.559	V.M.	1.86	1.92	+ .06	3.2
6637	.402	.281	.699	V.M.	1.87	1.95	+ .08	4.3
6645	.201	.140	.697	V.M.	.62	.66	+ .04	6.5

Check Tests, Bellvue Laboratory, 1926

7616	0.348	0.233	1.49	1.56	+0.07	4.7
7617	.935675	7.13	7.21	+ .08	1.1
7618	.937676	7.15	7.23	+ .08	1.1
7619	.942689	7.34	7.29	— .05	0.7
7620	.470323	2.40	2.48	+ .08	3.3
7621	.312208	1.26	1.31	+ .05	4.0
7622	.296195	1.15	1.21	+ .06	5.2
7623	.794572	5.59	5.59	.00	0.0
7624	.195125	.60	.63	+ .03	5.0
7627	.295196	1.16	1.21	+ .05	4.3
7628	.300196	1.16	1.24	+ .08	6.9
7630	.321215	1.33	1.38	+ .05	3.8
7633	.498344	2.64	2.71	+ .07	2.7
7637	.759546	5.21	5.22	+ .01	0.2
7642	.598422	3.57	3.60	+ .03	0.8
7644	0.747538	5.10	5.09	— .01	0.2
7648	1.214909	11.05	10.81	— .24	2.2
7655	1.028758	8.46	8.35	— .11	1.3
7656	1.372	1.035	13.38	13.06	— .32	2.4
7661	.856624	6.35	6.29	— .06	0.9
7736	.415666	2.02	2.05	+ .03	1.5
7737	.328445	1.42	1.43	+ .01	0.7
7738	.210276	.71	.71	.00	0.0
7741	.265356	1.02	1.02	.00	0.0
7745	.512713	2.83	2.84	+ .01	0.4
7750	.849	1.221	6.21	6.21	.00	0.0
7757	.968286	7.62	7.61	— .01	0.1
7758	1.776529	19.09	19.48	+ .39	2.0
7759	.834245	6.07	6.04	— .03	0.5
7762	2.142654	26.18	26.05	— .13	0.5
7763	2.250689	28.30	28.12	— .18	0.6
7768	1.575478	16.40	16.18	— .22	1.3
7773	1.135339	9.81	9.74	— .07	0.7

*Volumetric measurements, Hydraulic Laboratory, Fort Collins.

TABLE XVI.—ORIGINAL FREE-FLOW DISCHARGE DATA FOR 3-FOOT PARSHALL MEASURING FLUME, 1923

Test	Flume heads		Ratio H _b /H _a	Head on weir	Discharge		Difference	Deviation
	H _a	H _b			Obs.	Comp.		
	Feet	Feet		Feet	Sec.-ft.	Sec.-ft.	Sec.-ft.	Percent
6409	2.138	1.470	0.688	1.136	39.57	39.45	-0.12	0.3
6410	1.962	1.283	.654	1.042	34.78	34.48	-.30	0.9
6415	1.712	1.012	.591	.905	28.15	27.85	-.30	1.1
6416	1.597	.870	.545	.840	25.21	24.98	-.23	0.9
6421	1.377	.582	.423	.718	19.95	19.80	-.15	0.8
6422	1.154	.277	.240	.595	15.09	15.02	-.07	0.5
6423	1.167	.779	.668	.594	15.05	15.28	+.23	1.5
6427	.916	-.047460	10.23	10.46	+.18	1.7
6428	.719	-.306355	7.01	7.15	+.14	2.0
6432	.590	-.082285	5.07	5.25	+.18	3.5
6495	.800	-.146	V.M.*	8.62	8.46	-.16	1.9
6496	.800	.440	.550	V.M.	8.52	8.46	-.06	0.7
6497	.800	.547	.684	V.M.	8.40	8.46	+.06	0.7
6500	.892	-.017	V.M.	10.24	10.03	-.21	2.0
6501	.696	-.277	V.M.	6.87	6.80	-.07	1.0
6502	.588	-.410	V.M.	5.29	5.22	-.07	1.3
6503	.532	-.475	V.M.	4.51	4.47	-.04	0.9
6504	.391	-.189	V.M.	2.78	2.76	-.02	0.7
6505	.327	-.146	V.M.	2.09	2.09	.00	0.0
6506	.209	-.142	V.M.	1.03	1.03	.00	0.0
6507	1.202	.783	.651	V.M.	16.27	16.00	-.27	1.7
6513	.703	.463	.659	V.M.	6.85	6.91	+.06	0.9
6518	.502	-.077	V.M.	4.08	4.08	.00	0.0
6519	.499	.256	.513	V.M.	4.02	4.04	+.02	0.5
6527	.399	-.064	V.M.	2.86	2.85	-.01	0.4
6533	.601	.103	.171	V.M.	5.45	5.40	-.05	0.9
6542	.999	.124	.124	V.M.	12.27	11.98	-.29	2.4
6554	.600	.373	.622	V.M.	5.29	5.39	+.10	1.9
6564	1.098	.242	.220	V.M.	14.00	13.89	-.11	0.8
6572	1.200	.836	.697	V.M.	15.99	15.96	-.03	0.2
6574	.299	.073	.244	V.M.	1.77	1.81	+.04	2.3
7118	2.391	1.629	.682	1.262	46.20	46.99	+.79	1.7
7137	1.843	1.131	.614	.973	31.38	31.26	-.12	0.4
7138	1.141	.444	.389	.588	14.83	14.75	-.08	0.5

*Volumetric measurements, Hydraulic Laboratory, Fort Collins.

TABLE XVII.—ORIGINAL FREE-FLOW DISCHARGE DATA FOR 4-FOOT PARSHALL MEASURING FLUME, 1923

Test	Flume heads		Ratio H _b /H _a	Head on weir	Discharge		Difference	Deviation
	H _a	H _b			Obs.	Comp.		
	Feet	Feet		Feet	Sec.-ft.	Sec.-ft.	Sec.-ft.	Percent
6371	1.658	0.938	0.566	1.075	36.46	35.53	—0.93	2.5
6372	1.644	1.070	.651	1.060	35.69	35.06	— .63	1.8
6378	1.470	.704	.479	.952	30.38	29.38	—1.00	3.3
6379	2.001	1.309	.654	1.293	47.91	47.81	— .10	0.2
6380	1.994	1.300	.652	1.291	47.80	47.55	— .25	0.5
6381	1.973	1.286	.652	1.277	47.03	46.75	— .28	0.6
6386	2.219	1.548	.698	1.435	55.90	56.28	+ .38	0.7
6387	1.853	1.159	.626	1.202	43.00	42.35	— .65	1.5
6388	1.334	.516	.387	.850	25.66	25.22	— .44	1.7
6389	1.335	.525	.393	.845	25.44	25.25	— .19	0.7
6390	1.340	.828	.618	.848	25.57	25.39	— .18	0.7
6391	1.459	.694	.476	.935	29.56	29.04	— .52	1.8
6396	1.163	.271	.233	.730	20.45	20.30	— .15	0.7
6397	.958	— .008590	14.90	14.95	+ .05	0.3
6398	.966	.599	.620	.590	14.90	15.15	+ .25	1.7
6402	.738	— .293448	9.88	9.91	+ .03	0.3
6403	.595	— .456354	6.98	7.05	+ .07	1.0
6404	.485	— .029283	5.02	5.11	+ .09	1.8
6405	.598	.333	.557	.354	6.98	7.11	+ .13	1.9
7116	.864	— .186538	13.02	12.70	— .32	2.5
7117	1.295	.423	.326	.829	24.73	24.06	— .67	2.7
Check Tests, Bellvue Laboratory, 1926								
7456	0.729	0.340	9.85	9.72	—0.13	1.3
7461	.512232	5.60	5.56	— .04	0.7
7467	.264111	1.94	1.96	+ .02	1.0
7471	1.750855	39.05	38.69	— .36	0.9
7476	1.552760	32.75	32.01	— .74	2.3
7482	1.706837	37.83	37.16	— .67	1.8
7483	1.331642	25.47	25.13	— .34	1.3
7488	1.881922	43.71	43.36	— .35	0.8
7493	1.999981	47.95	47.73	— .22	0.5
7498	2.313	1.136	59.70	60.08	+ .38	0.6
7499	2.346	1.152	60.96	61.45	+ .49	0.8
7500	2.488	1.224	66.71	67.41	+ .70	1.0
7506	1.089519	18.55	18.31	— .24	1.3
7512	1.049	.675	.644	.493	17.18	17.25	+ .07	0.4
7517	1.607	1.058	.659	.779	33.99	33.82	— .17	0.5

TABLE XVIII.—ORIGINAL FREE-FLOW DISCHARGE DATA FOR 6-FOOT PARSHALL MEASURING FLUME, 1923

Test	Flume heads		Ratio H _b /H _a	Head on weir	Discharge		Difference	Deviation
	H _a	H _b			Obs.	Comp.		
	Feet	Feet		Feet	Sec.-ft.	Sec.-ft.	Sec.-ft.	Percent
6338	1.550	0.757	0.489	1.318	49.29	48.28	-1.01	2.1
6344	1.812	1.090	.601	1.548	62.54	61.94	-.60	1.0
6345	1.458	.640	.439	1.232	44.59	43.80	-.79	1.8
6346	1.368	.518	.379	1.153	40.46	39.57	-.89	2.2
6351	1.260	.379	.301	1.053	35.33	34.70	-.63	1.8
6352	1.139	.208	.183	.947	30.14	29.54	-.60	2.0
6357	1.005	.019	.019	.828	24.68	24.19	-.49	2.0
6358	.892	-.134725	20.24	20.00	-.24	1.2
6364	.737	-.332583	14.83	14.75	-.08	0.5
6365	.570	-.501445	9.79	9.79	.00	0.0
6369	.465	-.013356	7.03	7.08	+.05	0.7
6370	.382	-.035287	5.12	5.17	+.05	1.0
7070	2.158	1.476	.684	1.839	80.81	81.85	+1.04	1.3
7071	2.017	1.321	.655	1.722	73.31	73.49	+.18	0.2
7072	1.844	1.105	.599	1.567	63.70	63.68	-.02	0.3
7073	1.660	.858	.517	1.415	54.76	53.86	-.90	1.6
7074	1.498	.685	.457	1.270	46.64	45.72	-.92	2.0
7075	1.090	.121	.111	.904	28.10	27.53	-.57	2.0
7083	1.678	.870	.518	1.422	55.15	54.80	-.35	0.6
7084	1.511	.663	.438	1.250	45.55	46.36	+.81	1.8

Check Tests, Bellvue Laboratory, 1926

7389	0.326	0.186	4.04	4.02	-0.02	0.5
7394	.628376	11.45	11.43	-.02	0.2
7399	.742448	14.88	14.91	+.03	0.2
7400	.755	0.524	0.694	.447	14.83	15.33	+.50	3.4
7403	.756460	15.48	15.36	-.12	0.8
7408	.899552	20.33	20.25	-.08	0.4
7417	1.023636	25.11	24.89	-.22	0.9
7418	1.151722	30.34	30.04	-.30	1.0
7428	2.239	1.556	.695	1.444	85.29	86.81	+1.52	1.8
7433	2.142	1.445	.675	1.332	79.92	80.87	+.95	1.2
7434	2.114	1.475	.698	1.352	77.36	79.21	+1.85	2.4
7438	1.975	1.262	.639	1.272	70.66	71.07	+.41	0.6
7443	1.792	1.041	.581	1.149	60.72	60.85	+.13	0.2
7446	1.570	1.014	50.39	49.28	-1.11	2.2
7451	1.375878	40.63	39.89	-.74	1.8

TABLE XIX.—ORIGINAL FREE-FLOW DISCHARGE DATA FOR 8-FOOT PARSHALL MEASURING FLUME, 1923

Test	Flume heads		Ratio H _b /H _a	Head on weir	Discharge			Deviation
	H _a	H _b			Obs.	Comp.	Difference	
	Feet	Feet		Feet	Sec.-ft.	Sec.-ft.	Sec.-ft.	Percent
6295	1.400	0.905	0.646	1.400	53.90	54.95	+1.05	2.0
6300	1.318	.436	.331	1.323	49.57	49.87	+ .30	0.6
6301	1.239	.315	.254	1.240	45.01	45.16	+ .15	0.3
6302	1.235	.540	.437	1.237	44.85	44.93	+ .08	0.2
6303	1.244	.728	.585	1.244	45.23	45.45	+ .22	0.5
6304	1.246	.871	.689	1.242	45.12	45.57	+ .45	1.0
6309	1.101	.109	.099	1.097	37.68	37.95	+ .23	0.6
6310	1.049	.047	.045	1.044	34.88	34.56	— .32	0.9
6311	1.052	.533	.507	1.046	34.98	34.72	— .26	0.7
6312	1.056	.624	.591	1.048	35.08	34.93	— .15	0.4
6317	.975	— .060	—	.961	30.81	30.73	— .08	0.3
6318	.858	— .218	—	.833	25.12	25.02	— .10	0.4
6319	.859	.220	.256	.841	25.26	25.06	— .20	0.8
6320	.860	.448	.522	.840	25.21	25.11	— .10	0.4
6321	.863	.526	.651	.837	25.08	25.25	+ .17	0.7
6324	.748	.096	.128	.726	20.28	20.05	— .23	1.1
6325	.625	.049	.078	.596	15.12	15.03	— .09	0.6
6326	.625	.235	.376	.596	15.12	15.03	— .09	0.6
6330	.479	.010	.021	.449	9.92	9.81	— .11	1.1
6332	.314	— .044	—	.282	4.99	4.98	— .01	0.2
6333	.369	— .102	—	.340	6.57	6.45	— .12	1.8
6336	1.443	.925	.641	1.470	57.92	57.69	— .23	0.4
6337	1.313	.397	.302	1.326	49.74	49.56	— .18	0.4
7044	.452	.131	.290	.422	9.04	8.93	— .11	1.2
7045	.611	.317	.519	.586	14.75	14.50	— .25	1.7
7060	1.660	1.214	.677	1.689	71.23	72.26	+1.03	1.4
7064	1.567	1.082	.690	1.598	65.59	65.86	+ .27	0.4
7066	1.296	.380	.293	1.295	48.02	48.54	+ .52	1.1
7067	1.513	.944	.624	1.519	60.80	62.26	+1.46	2.4

Check Tests, Bellvue Laboratory, 1926

Mean Width of Throat, 7.98 Feet

7285	1.517	—	—	1.204	65.10	62.36	—2.74	4.2
7286	1.489	—	—	1.180	63.18	60.52	—2.66	4.2
7290	1.084	—	—	.840	38.03	36.34	—1.69	4.4
7291	1.066	—	—	.824	36.96	35.37	—1.59	4.3
7292	1.063	—	—	.824	36.96	35.21	—1.75	4.7
7293	.822	—	—	.685	25.06	23.29	—1.77	7.1
7294	.828	—	—	.631	24.82	23.54	—1.28	5.2
7295	1.425	—	—	1.124	58.76	56.40	—2.36	4.0
7300	.446	—	—	.324	9.17	8.72	— .45	4.9
7301	.448	.064	.143	.324	9.17	8.79	— .38	4.1
7302	.449	.192	.428	.326	9.25	8.82	— .43	4.7
7303	.452	.315	.697	.326	9.25	8.93	— .32	3.5
7306	.746	—	—	.560	20.77	19.91	— .86	4.2
7307	.755	.523	.693	.555	20.50	20.81	+ .31	0.9
7310	.443	—	—	.313	8.71	8.63	— .08	0.9
7311	.762	—	—	.564	20.99	20.61	— .38	1.8
7312	.986	—	—	.744	31.73	31.21	— .52	1.6
7317	1.153	—	—	.883	40.98	40.13	— .85	2.1
7322	1.410	—	—	1.099	56.82	55.44	—1.38	2.4
7327	1.508	.814	.540	1.176	62.86	61.78	—1.08	1.7
7328	1.615	1.001	.661	1.176	62.86	62.23	— .63	1.0
7338	1.570	.975	.621	1.220	66.39	65.90	— .49	0.7
7346	.343	— .079	—	.240	5.89	5.73	— .16	2.7
7347	.344	.221	.642	.240	5.89	5.76	— .13	2.2
7350	.628	.167	.266	.458	15.38	15.11	— .27	1.8
7351	.629	.364	.579	.458	15.38	15.15	— .23	1.5
7353	.634	.429	.677	.459	15.43	15.35	— .08	0.5
7355	1.404	.800	.570	1.090	56.13	55.06	—1.07	1.9
7358	1.402	.832	.594	1.078	55.21	54.94	— .27	0.5
7359	1.806	.976	.540	1.416	82.85	82.62	— .23	0.4
7364	1.696	.849	.500	1.332	75.67	74.61	—1.06	1.4
7369	.730	—	—	.539	19.63	19.24	— .39	2.0
7378	.788	—	—	.581	21.94	21.77	— .17	0.8

Mean Width of Throat, 8.00 Feet								
7518	1.289	0.992	48.76	48.11	-0.65	1.3
7519	1.500	1.152	60.96	61.40	+ .44	0.7
7523	1.345	1.031	51.66	51.53	- .13	0.3
7524	1.351	0.818	0.605	1.027	51.36	51.90	+ .54	1.1
7528	1.116	1.842	38.17	38.17	.00	0.0
7529	1.119	.608	.544	.845	38.37	38.33	- .04	0.1
7534	.973730	30.84	30.88	+ .04	0.1
7535	.980	.629	.642	.730	30.84	30.98	+ .14	0.5
7540	.861638	25.23	25.16	- .07	0.3
7541	.858	.570	.664	.633	24.94	25.02	+ .08	0.3
7545	.609438	14.39	14.42	+ .03	0.2
7550	.389273	7.12	7.02	- .10	1.4
7553	.262178	3.79	3.72	- .07	1.8
7554	.306212	4.91	4.78	- .13	2.6

TABLE XX.—ORIGINAL SUBMERGED-FLOW DATA FOR 3-INCH PARSHALL MEASURING FLUME, 1930

Test	Flume heads		Ratio H _u /H _a	Loss of head†		Head on weir	Discharge		Difference	Deviation
	H _a	H _b		Obs.	Comp.		Obs.	Comp.		
8186	1.000	0.951	0.951	0.04	0.04	Feet	0.506	0.510**	+0.004	0.8
8183	1.000	.906	.90608	V.M.*	.657	.657	.000	0.0
8184	.999	.810	.810	.23	.24	V.M.	.826	.828	+ .002	0.2
8185	.999	.698	.698	.41	.42	V.M.	.940	.940	.000	0.0
8195	.702	.665	.947	.02	.03	V.M.	.296	.306	+ .010	3.4
8190	.704	.633	.899	.07	.06	V.M.	.404	.404	.000	0.0
8189	.700	.563	.804	.15	.15	V.M.	.491	.493	+ .002	0.4
8188	.701	.510	.727	.23	.23	V.M.	.530	.538	+ .008	1.5
8194	.401	.376	.938	.02	V.M.	.138	.145	+ .007	5.1
8193	.401	.341	.850	.06	.06	V.M.	.204	.201	— .003	1.5
8192	.400	.309	.772	.09	.09	V.M.	.221	.223	+ .002	0.9
8191	.399	.252	.632	.14	.17	V.M.	.237	.240	+ .003	1.3
8197	.202	.195	.965	.01	V.M.	.038	.039	+ .001	2.6
8200	.198	.179	.904	.02	V.M.	.056	.060	+ .004	7.1
8196	.201	.169	.841	.03	V.M.	.074	.073	— .001	1.4
8199	.199	.151	.759	.05	V.M.	.078	.078	.000	0.0
8198	.200	.141	.705	.05	V.M.	.080	.081	— .001	1.2

*Volumetric measurements, Hydraulic Laboratory, Fort Collins.

**The computed discharge determined from diagram figure 14.

†For tables XX to XXVIII, inclusive, original submerged-flow data, the computed loss of head is based on the diagram, figure 18.

TABLE XXI—ORIGINAL SUBMERGED-FLOW DISCHARGE DATA FOR THE 6-INCH PARSHALL MEASURING FLUME, 1926

Test	Flume heads		Ratio H _b /H _a	Loss of head		Head on weir		Discharge		Difference Sec.-ft.	Deviation Percent
	H _a	H _b		Obs.	Comp.	Feet	Comp.	Obs.	Sec.-ft.		
7234	0.511	0.263	0.511	0.23	0.24	0.23	0.24	0.72	0.72	0.00	0.0
7235	0.508	0.344	0.678	0.15	0.14	0.15	0.14	0.68	0.68	0.00	0.0
7236	0.533	0.411	0.771	0.10	0.10	0.10	0.10	0.69	0.69	0.00	0.0
7237	0.558	0.449	0.805	0.05	0.08	0.05	0.08	0.64	0.73	0.09	14.1
7238	0.566	0.510	0.901	0.02	0.03	0.02	0.03	0.58	0.58	0.00	0.0
7239	0.588	0.556	0.946	0.01	0.01	0.01	0.01	0.44	0.42	0.02	4.6
7240	0.581	0.510	0.909	0.02	0.03	0.02	0.03	0.50	0.55	0.05	10.0
7241	0.550	0.509	0.850	0.03	0.23	0.03	0.23	0.52	1.33	0.81	0.7
7242	0.374	0.374	0.900	0.25	0.26	0.25	0.26	1.34	1.33	0.00	0.0
7243	0.369	0.351	0.950	0.20	0.21	0.20	0.21	1.46	1.48	0.00	0.0
7244	0.362	0.338	0.850	0.15	0.15	0.15	0.15	1.38	1.38	0.00	0.0
7245	0.391	0.366	0.860	0.10	0.11	0.10	0.11	1.35	1.33	0.02	1.5
7246	0.395	0.315	0.811	0.07	0.07	0.07	0.07	1.17	1.14	0.03	2.6
7247	0.345	0.379	0.930	0.05	0.06	0.05	0.06	1.13	1.13	0.00	0.0
7248	0.326	0.371	0.940	0.04	0.04	0.04	0.04	1.05	1.00	0.05	4.8
7249	0.340	0.378	0.933	0.05	0.05	0.05	0.05	1.12	1.08	0.04	3.6
7250	0.336	0.321	0.874	0.06	0.08	0.06	0.08	1.12	1.08	0.04	3.6
7251	0.322	0.321	0.874	0.06	0.06	0.06	0.06	0.33	0.33	0.00	0.0
7252	0.351	0.328	0.834	0.03	0.03	0.03	0.03	0.22	0.22	0.00	0.0
7253	0.351	0.328	0.834	0.03	0.03	0.03	0.03	0.22	0.22	0.00	0.0
7254	0.217	0.173	0.798	0.01	0.01	0.01	0.01	0.385	0.385	0.00	0.0
7255	0.219	0.163	0.745	0.03	0.03	0.03	0.03	0.331	0.16	0.17	4.4
7256	0.219	0.151	0.690	0.05	0.05	0.05	0.05	0.339	0.18	0.16	0.0
7257	0.217	0.146	0.673	0.05	0.05	0.05	0.05	0.344	0.18	0.16	0.0
7258	0.218	0.135	0.618	0.06	0.06	0.06	0.06	0.17	0.18	0.01	5.9
7259	0.219	0.129	0.585	0.06	0.06	0.06	0.06	0.350	0.19	0.16	0.0
7260	0.207	0.207	0.945	0.01	0.01	0.01	0.01	0.09	0.09	0.00	0.0
7261	0.216	0.184	0.852	0.01	0.02	0.01	0.02	0.264	0.10	0.16	11.1
7262	0.216	0.195	0.902	0.00	0.00	0.00	0.00	0.313	0.14	0.17	14.3
7263	0.461	0.275	0.597	0.17	0.17	0.17	0.17	0.293	0.12	0.12	0.0
7264	0.458	0.246	0.537	0.19	0.20	0.19	0.20	0.60	0.60	0.00	0.0
7265	0.460	0.343	0.745	0.10	0.09	0.10	0.09	0.569	0.56	0.00	0.0
7266	0.459	0.385	0.839	0.07	0.06	0.07	0.06	0.566	0.57	0.01	1.8
7267	0.462	0.429	0.928	0.01	0.01	0.01	0.01	0.541	0.52	0.02	3.9
7268	0.456	0.437	0.958	0.01	0.01	0.01	0.01	0.34	0.32	0.02	6.0
7269	0.721	0.550	0.762	0.17	0.16	0.17	0.16	0.457	0.35	0.10	28.0
7270	0.724	0.488	0.674	0.23	0.23	0.23	0.23	0.95	1.10	0.15	0.9
7271	0.721	0.414	0.574	0.30	0.31	0.30	0.31	1.17	1.17	0.00	0.0
7272	0.614	0.510	0.833	0.10	0.10	0.10	0.10	1.20	1.20	0.00	0.0
7273	0.588	0.517	0.877	0.13	0.12	0.13	0.12	1.02	0.99	0.03	2.9
7274	0.715	0.643	0.899	0.05	0.05	0.05	0.05	1.05	1.04	0.01	1.0
7275	0.664	0.624	0.924	0.02	0.04	0.02	0.04	0.84	0.84	0.00	0.0
7276	0.632	0.632	0.935	0.37	0.36	0.37	0.36	0.71	0.74	0.03	4.2
7277	0.995	0.701	0.700	0.30	0.30	0.30	0.30	1.33	1.33	0.00	0.0
7278	1.002	0.701	0.700	0.30	0.30	0.30	0.30	1.33	1.33	0.00	0.0
7279	1.001	0.779	0.779	0.22	0.21	0.22	0.21	1.89	1.89	0.00	0.0
7280	0.998	0.819	0.820	0.16	0.17	0.16	0.17	1.79	1.71	0.08	0.0
7281	0.999	0.884	0.884	0.11	0.10	0.11	0.10	1.70	1.71	0.01	0.6
7282	0.999	0.915	0.915	0.06	0.07	0.06	0.07	1.51	1.50	0.01	0.7
7283	1.005	0.947	0.947	0.02	0.04	0.02	0.04	1.31	1.33	0.02	1.5
7284	0.997	0.928	0.928	0.00	0.06	0.00	0.06	1.17	1.23	0.06	5.1

TABLE XXII—ORIGINAL SUBMERGED-FLOW DATA FOR 9-INCH
PARSHALL MEASURING FLUME, 1930

Test	Plume heads H _a	Plume heads H _b	Ratio H _b /H _a	Head on weir	Discharge Obs.	Discharge Comp.	Difference	Deviation
	Feet	Feet		Feet	Sec.-ft.	Sec.-ft.	Sec.-ft.	Percent
8500	0.233	0.164	0.704	0.122	0.30	0.30*	0.00	0.0
8501	.300	.272	.906	.122	.30	.30	— .00	0.0
8502	.242	.175	.723	.121	.29	.31	+ .02	6.9
8503	.291	.263	.904	.120	.29	.28	— .01	3.4
8504	.271	.232	.856	.120	.29	.29	— .00	0.0
8505	.252	.202	.802	.119	.29	.29	— .00	0.0
8506	.244	.187	.766	.119	.29	.30	+ .01	3.4
8507	.343	.322	.939	.122	.30	.32	+ .02	6.7
8508	.226	.144	.637	.122	.30	.29	— .01	3.3
8509	.627	.544	.869	.294	1.06	1.13	+ .07	6.6
8510	.527	.354	.672	.300	1.10	1.11	+ .01	0.9
8511	.578	.464	.802	.296	1.08	1.16	+ .08	7.4
8512	.512	.331	.646	.292	1.05	1.08	+ .03	2.8
8513	.625	.548	.877	.285	1.02	1.11	+ .09	8.8
8514	.745	.693	.931	.302	1.11	1.12	+ .01	0.9
8515	.528	.375	.710	.294	1.08	1.09	+ .01	0.9
8516	.525	.388	.739	.294	1.06	1.06	— .00	0.0
8517	.545	.433	.794	.300	1.10	1.08	— .02	1.8
8518	.951	.794	.835	.515	2.48	2.41	— .07	2.8
8519	.993	.857	.864	.513	2.46	2.39	— .07	2.8
8520	1.044	.927	.888	.500	2.37	2.38	+ .01	0.4
8521	1.206	1.100	.912	.508	2.43	2.64	+ .21	8.6
8522	1.257	1.175	.934	.498	2.36	2.45	+ .09	3.8
8523	.866	.545	.630	.506	2.41	2.42	+ .01	0.4
8524	.913	.721	.790	.512	2.45	2.47	+ .02	0.8
8525	.865	.577	.675	.499	2.36	2.37	+ .01	0.4
8526	.940	.772	.821	.508	2.43	2.43	— .00	0.0
8527	.924	.753	.815	.500	2.37	2.39	+ .02	0.8
8528	.859	.618	.720	.497	2.35	2.33	— .02	0.9
8529	.886	.697	.786	.499	2.36	2.33	— .03	1.3
8531	.886	.697	.786	.499	2.36	2.33	— .03	1.3
8533	.566	.413	.743	.313	1.17	1.16	— .01	0.9
8534	.641	.548	.855	.309	1.15	1.23	+ .08	7.0
8535	.309	.240	.777	.168	.46	.44	— .02	4.3
8536	.446	.419	.939	.167	.46	.47	+ .01	2.2
8537	.334	.267	.799	.169	.47	.48	+ .01	2.1
8538	.446	.292	.655	.263	.85	.86	+ .05	5.5
8539	.515	.429	.833	.252	.85	.93	+ .08	9.4
8540	.461	.348	.755	.247	.83	.85	+ .02	2.4
8541	.787	.672	.854	.380	1.57	1.73	+ .16	10.2
8542	.648	.456	.704	.369	1.49	1.51	+ .02	1.3
8543	.665	.544	.817	.374	1.53	1.43	— .10	6.5
8544	.820	.734	.895	.376	1.54	1.55	+ .01	0.6
8545	.869	.800	.920	.375	1.54	1.52	— .02	1.3
8546	.519	.406	.782	.271	.95	1.01	+ .06	6.3
8547	.632	.576	.911	.270	.94	.96	+ .02	2.1
8548	.253	.216	.853	.116	.28	.27	— .01	3.6
8549	.272	.244	.897	.116	.28	.27	— .01	3.6

*The computed discharge determined from diagram, figure 16.

TABLE XXIII.—ORIGINAL SUBMERGED-FLOW DISCHARGE DATA FOR THE 1-FOOT PARSHALL MEASURING FLUME, 1923

Test	Flume heads		Ratio H _b /H _a	Loss of head		Head on weir	Discharge		Difference	Deviation
	H _a	H _b		Obs.	Comp.		Obs.	Comp.		
6482	2.524	1.926	0.763	0.65	0.63	0.593	15.01	15.01	0.00	0.0
6488	1.564	1.203	.770	.50	.40	.371	7.47	7.33	-.14	1.9
6489	1.779	1.522	.856	.23	.26	.375	7.59	7.88	+.29	3.8
6490	2.130	1.966	.924	.12	.16	.371	7.47	8.10	+.63	8.4
6492	2.012	1.637	.814	.43	.39	.449	9.92	10.15	+.23	2.3
6493	2.196	1.916	.873	.28	.28	.451	9.98	10.27	+.29	2.9
6667	.600	.424	.707	.17	.17	V.M.*	1.74	1.75	+.01	0.6
6668	.598	.513	.858	.09	.09	V.M.	1.61	1.54	-.07	4.3
6669	1.800	1.262	.701	.64	.59	V.M.	9.50	9.44	-.06	0.6
6670	1.799	1.394	.775	.47	.43	V.M.	9.05	9.00	-.05	0.6
6671	1.799	1.514	.842	.32	.31	V.M.	8.48	8.24	-.24	2.8
6672	1.801	1.712	.950	.08	.09	V.M.	5.54	5.33	-.21	3.8
6674	1.604	1.126	.702	.54	.51	V.M.	7.98	7.92	-.06	0.8
6675	1.603	1.200	.749	.46	.44	V.M.	7.73	7.71	-.02	0.3
6676	1.597	1.360	.852	.28	.25	V.M.	7.02	6.78	-.24	3.4
6677	1.602	1.514	.945	.07	.08	V.M.	4.86	4.66	-.20	4.1
6679	1.405	1.096	.780	.34	.33	V.M.	6.24	6.20	-.04	0.6
6680	1.400	1.000	.714	.43	.42	V.M.	6.43	6.43	0.00	0.0
6681	1.402	1.205	.860	.21	.21	V.M.	5.74	5.52	-.22	3.8
6682	1.402	1.333	.950	.06	.08	V.M.	3.79	3.66	-.13	3.4
6686	1.202	.857	.713	.37	.37	V.M.	5.10	5.09	-.01	0.2
6687	1.199	.914	.763	.31	.31	V.M.	4.98	4.94	-.04	0.8
6688	1.199	1.024	.854	.18	.20	V.M.	4.58	4.42	-.16	3.5
6689	1.001	.759	.758	.26	.25	V.M.	3.78	3.78	0.00	0.0
6690	1.000	.714	.714	.30	.30	V.M.	3.83	3.85	+.02	0.5
6691	1.000	.850	.850	.12	.16	V.M.	3.33	3.40	+.07	2.1
6692	.998	.948	.950	.04	.06	V.M.	2.34	2.18	-.16	6.8
6694	.802	.605	.754	.21	.21	V.M.	2.69	2.70	+.01	0.4
6695	.801	.568	.709	.24	.25	V.M.	2.72	2.75	+.03	1.1
6696	.800	.681	.851	.10	.13	V.M.	2.32	2.43	+.11	4.8
6699	.599	.448	.748	.15	.15	V.M.	1.71	1.73	+.02	1.2
6702	.402	.307	.764	.09	.10	V.M.	.91	.90	-.01	1.1
6704	.398	.349	.877	.05	.05	V.M.	.78	.77	-.01	1.3
6709	1.801	1.392	.772	.48	.43	V.M.	9.11	9.04	-.07	0.8
6710	1.002	.708	.706	.31	.31	V.M.	3.86	3.87	+.01	0.3
6712	.800	.677	.846	.10	.13	V.M.	2.33	2.45	+.12	5.1
6713	.801	.633	.790	.17	.18	V.M.	2.63	2.63	0.00	0.0

*Volumetric measurements, Hydraulic Laboratory, Fort Collins.

TABLE XXIII.—ORIGINAL SUBMERGED-FLOW DISCHARGE DATA FOR THE 1-FOOT PARSHALL MEASURING FLUME, 1923
(Concluded)

Check Tests Bellvue Laboratory, 1926

Test	Flume heads		Ratio H _b /H _a	Loss of head		Head on weir	Discharge		Difference	Deviation
	H _a	H _b		Obs.	Comp.		Obs.	Comp.		
	Feet	Feet		Feet	Feet	Feet	Sec.-ft.	Sec.-ft.	Sec.-ft.	Percent
7663	1.447	1.349	0.932	0.11	0.10	0.487	4.41	4.39	-0.02	0.5
7664	1.381	1.250	.905	.11	.13	.497	4.54	4.70	+ .16	3.5
7665	1.276	1.081	.848	.20	.20	.521	4.87	4.91	+ .04	0.8
7666	1.233	1.000	.811	.28	.26	.530	4.99	4.93	- .06	1.2
7669	1.964	1.613	.822	.44	.36	.844	9.91	9.69	- .22	2.2
7670	1.928	1.494	.775	.57	.47	.861	10.21	9.97	- .24	2.3
7671	2.078	1.857	.894	.17	.22	.781	8.84	8.90	+ .06	0.7
7673	.641	.462	.721	.16	.18	.268	1.83	1.93	+ .10	5.5
7675	.330	.277	.840	.05	.05	.123	.59	.60	+ .01	1.7
7676	.343	.300	.875	.07	.04	.124	.60	.59	- .01	1.7
7677	.344	.302	.878	.07	.04	.124	.60	.58	- .02	3.3
7678	.353	.315	.892	.07	.04	.124	.60	.58	- .02	3.3
7681	.514	.409	.796	.13	.11	.210	1.28	1.32	+ .04	3.1
7682	.516	.420	.814	.12	.10	.210	1.28	1.30	+ .02	1.6
7683	.556	.495	.890	.05	.07	.201	1.21	1.26	+ .05	4.1
7685	.290	.245	.845	.07	.04	.107	.48	.48	.00	0.0
7686	.283	.209	.739	.08	.08	.113	.52	.52	.00	0.0
7687	.337	.312	.926	.04	.02	.103	.45	.46	+ .01	2.2
7688	.337	.310	.920	.05	.02	.109	.49	.48	- .01	2.0
7690	.622	.482	.775	.12	.14	.255	1.70	1.79	+ .09	5.3
7691	.690	.627	.909	.07	.06	.244	1.59	1.63	+ .04	2.5
7693	1.456	1.332	.915	.09	.13	.508	4.69	4.86	+ .17	3.6
7694	1.512	1.412	.934	.10	.10	.498	4.55	4.62	+ .07	1.5
7696	2.496	2.087	.836	.56	.39	1.054	13.74	13.42	- .32	2.3
7697	2.489	2.245	.902	.24	.24	.913	11.12	11.20	+ .08	0.7
7698	2.486	2.319	.933	.14	.16	.815	9.42	9.66	+ .24	2.5
7700	2.284	1.968	.862	.38	.33	.925	11.34	11.18	- .16	1.4
7701	2.393	2.182	.912	.16	.20	.844	9.91	10.18	+ .27	2.7
7702	2.285	1.826	.817	.53	.41	.955	11.89	11.79	- .10	0.8
7705	1.758	1.540	.876	.20	.21	.682	7.24	7.37	+ .13	1.8
7706	1.950	1.831	.940	.11	.11	.624	6.35	6.48	+ .13	2.0
7707	1.612	1.188	.737	.53	.45	.723	7.89	7.85	- .04	0.5
7709	1.213	1.130	.932	.07	.09	.404	3.35	3.37	+ .02	0.6
7710	1.101	.941	.855	.12	.17	.425	3.61	3.89	+ .28	7.7
7711	1.015	.825	.813	.24	.21	.432	3.70	3.67	- .03	0.8
7719	.298	.246	.826	.06	.05	.227	.53	.52	- .01	1.9
7722	.474	.406	.856	.09	.07	.364	1.06	1.07	+ .01	0.9
7723	.447	.320	.716	.14	.14	.368	1.07	1.10	+ .03	2.8
7724	.635	.531	.836	.11	.11	.498	1.67	1.74	+ .07	4.2
7726	.775	.619	.820	.16	.16	.630	2.36	2.32	- .04	1.7
7727	.869	.787	.906	.09	.09	.617	2.29	2.35	+ .06	2.6
7728	1.463	1.191	.815	.34	.28	1.243	6.37	6.33	- .04	0.6
7729	1.651	1.494	.905	.12	.16	1.177	5.89	6.10	+ .21	3.6

TABLE XXIV.—ORIGINAL SUBMERGED-FLOW DISCHARGE DATA FOR THE 2-FOOT PARSHALL MEASURING FLUME, 1923

Test	Flume heads		Ratio H _b /H _a	Loss of head		Head on weir	Discharge		Difference	Deviation
	H _a	H _b		Obs.	Comp.		Obs.	Comp.		
	Feet	Feet		Feet	Feet	Feet	Sec.-ft.	Sec.-ft.	Sec.-ft.	Percent
6434	2.516	1.791	0.712	1.007	33.03	31.97	-1.06	3.2
6436	2.495	1.956	.784	0.67	0.60	.949	30.23	30.03	-.20	0.7
6439	2.260	1.792	.793	.51	.48	.835	24.99	25.66	+ .67	2.7
6440	2.370	1.964	.829	.35	.42	.834	24.95	26.37	+1.42	5.7
6445	1.528	1.090	.714	.48	.50	.590	14.90	14.88	-.02	0.1
6446	1.738	1.442	.831	.21	.19	.592	14.97	16.51	+1.54	10.3
6447	2.168	2.042	.943	.10	.12	.583	14.64	16.47	+1.83	12.5
6451	1.204	1.076	.894	.10	.13	.371	7.47	8.29	+ .82	11.0
6454	2.517	1.788	.711	1.015	33.43	32.01	-1.42	4.2
6602	1.403	1.038	.741	.41	.41	V.M.*	13.23	12.91	-.32	2.4
6603	1.397	1.187	.850	.20	.23	V.M.	11.30	11.53	+ .23	2.0
6604	1.003	.859	.856	.16	.14	V.M.	6.90	6.89	-.01	0.1
6606	1.002	.707	.706	.31	.33	V.M.	7.89	7.77	-.12	1.5
6607	1.000	.768	.768	.26	.26	V.M.	7.70	7.55	-.15	2.0
6608	.999	.860	.860	.16	.15	V.M.	6.85	6.79	-.06	0.9
6609	1.000	.948	.948	.06	.06	V.M.	5.06	4.81	-.25	5.0
6612	1.602	1.127	.704	.51	.54	V.M.	16.51	16.09	-.42	2.5
6613	1.593	1.217	.764	.42	.42	V.M.	15.89	15.48	-.41	2.6
6614	1.604	1.359	.847	.22	.26	V.M.	14.24	14.26	+ .02	0.1
6615	1.602	1.499	.936	.12	.12	V.M.	10.99	10.80	-.19	1.7
6617	1.598	1.350	.845	.24	.26	V.M.	14.35	14.23	-.12	0.8
6618	1.407	1.333	.947	.09	.08	V.M.	8.52	8.28	-.24	2.8
6620	1.200	.905	.754	.32	.34	V.M.	10.32	10.07	-.25	2.4
6621	1.402	1.000	.714	.43	.46	V.M.	13.46	13.04	-.42	3.1
6622	1.206	.875	.726	.35	.37	V.M.	10.50	10.29	-.21	2.0
6623	1.203	1.026	.853	.19	.19	V.M.	9.21	9.14	-.07	0.8
6626	.802	.584	.728	.22	.24	V.M.	5.51	5.45	-.06	1.1
6627	.802	.618	.770	.19	.21	V.M.	5.45	5.34	-.11	2.0
6628	.802	.692	.863	.10	.12	V.M.	4.60	4.83	+ .23	5.0
6629	.803	.753	.944	.05	.05	V.M.	3.50	3.51	+ .01	0.3
6631	.598	.421	.704	.16	.19	V.M.	3.49	3.46	-.03	0.9
6632	.602	.456	.757	.13	.16	V.M.	3.38	3.42	+ .04	1.2
6633	.601	.514	.855	.09	.10	V.M.	3.06	3.11	+ .05	1.6
6634	.596	.562	.943	.04	.04	V.M.	2.29	2.16	-.13	5.7
6637	.402	.281	.700	.12	.13	V.M.	1.87	1.82	-.05	2.7
6638	.402	.298	.741	.10	.11	V.M.	1.82	1.81	-.01	0.6
6639	.400	.352	.880	.06	.05	V.M.	1.60	1.53	-.07	4.4

*Volumetric measurements, Hydraulic Laboratory, Fort Collins.

TABLE XXIV.—ORIGINAL SUBMERGED-FLOW DISCHARGE DATA FOR THE 2-FOOT PARSHALL MEASURING FLUME, 1923
(Continued)
Check Tests, Bellvue Laboratory, 1926

Test	Flume heads		Ratio H _b /H _a	Loss of head		Head on weir	Discharge		Difference	Deviation
	H _a	H _b		Obs.	Comp.		Obs.	Comp.		
	Feet	Feet		Feet	Feet	Feet	Sec.-ft.	Sec.-ft.	Sec.-ft.	Percent
7629	0.319	0.272	0.853	0.06	0.05	0.194	1.14	1.11	-0.03	2.6
7631	.334	.260	.779	.09	.08	.214	1.32	1.30	-.02	1.5
7632	.372	.339	.912	.04	.04	.212	1.30	1.21	-.09	6.9
7634	.515	.371	.720	.15	.16	.345	2.66	2.70	+ .04	1.5
7635	.561	.487	.868	.04	.08	.342	2.62	2.73	+ .11	4.2
7636	.627	.581	.927	.06	.05	.337	2.56	2.64	+ .08	3.1
7638	.804	.599	.745	.19	.21	.544	5.19	5.43	+ .24	4.6
7639	.847	.705	.832	.13	.15	.540	5.13	5.51	+ .38	7.4
7640	.978	.907	.928	.08	.07	.524	4.91	5.30	+ .39	7.9
7641	1.634	1.535	.940	.10	.09	.846	9.94	10.89	+ .95	9.6
7643	.653	.544	.834	.11	.12	.416	3.49	3.67	+ .18	5.2
7645	.788	.599	.760	.17	.20	.533	5.03	5.22	+ .19	3.8
7646	.822	.683	.831	.14	.15	.532	5.02	5.27	+ .25	5.0
7647	1.057	.927	.877	.12	.13	.650	6.75	7.16	+ .41	6.1
7649	1.276	.998	.782	.28	.31	.896	10.82	10.86	+ .04	0.4
7650	1.374	1.180	.859	.17	.20	.875	10.45	11.06	+ .61	5.8
7651	1.149	.938	.817	.18	.22	.758	8.46	9.01	+ .55	6.5
7652	1.112	.877	.789	.21	.25	.749	8.31	8.75	+ .44	5.3
7653	1.241	1.131	.912	.11	.12	.714	7.74	8.19	+ .45	5.8
7654	1.203	1.084	.901	.11	.12	.708	7.65	8.13	+ .48	6.3
7657	1.582	1.405	.888	.15	.17	.963	12.03	12.80	+ .77	6.4
7658	1.635	1.492	.913	.12	.14	.934	11.50	12.39	+ .89	7.7
7659	1.023	.935	.915	.10	.09	.584	5.76	6.02	+ .26	4.5
7660	.906	.692	.764	.20	.22	.610	6.14	6.49	+ .35	5.7
7742	.275	.219	.797	.09	.06	.351	1.00	.92	-.08	8.0
7743	.285	.245	.860	.06	.05	.351	1.00	.91	-.09	9.0
7744	.311	.286	.920	.03	.03	.348	.98	.86	-.12	12.2
7746	.529	.419	.792	.13	.13	.709	2.80	2.73	-.07	2.5
7747	.535	.414	.774	.13	.13	.711	2.82	2.81	-.01	0.4
7748	.543	.451	.823	.06	.11	.709	2.80	2.81	+ .01	0.4
7749	.621	.572	.921	.08	.06	.697	2.74	2.70	-.04	1.5
7751	.902	.697	.773	.20	.22	1.211	6.14	6.41	+ .27	4.4
7752	1.056	.975	.923	.10	.09	1.171	5.85	6.10	+ .25	4.3
7753	.984	.869	.884	.12	.13	1.191	5.99	6.27	+ .28	4.7
7754	.992	.750	.814	.18	.18	1.202	6.07	6.42	+ .35	5.8
7755	.880	.660	.750	.25	.24	1.213	6.15	6.24	+ .09	1.5
7756	0.943	.792	.840	.15	.16	1.203	6.08	6.45	+ .37	6.1
7760	1.009	.917	.909	.10	.10	.237	5.78	6.04	+ .26	4.5
7761	1.018	.930	.914	.10	.09	.237	5.78	5.99	+ .21	3.6
7764	2.380	1.981	.833	.45	.42	.650	25.94	26.43	+ .49	1.9
7765	2.488	2.185	.879	.26	.30	.624	24.41	25.81	+1.40	5.7
7766	2.454	2.266	.924	.18	.18	.550	20.22	21.88	+1.66	8.2
7767	2.330	1.856	.810	.57	.48	.658	26.42	26.36	-.06	0.2
7769	1.603	1.305	.814	.30	.31	.440	14.49	14.94	+ .45	3.1
7770	1.704	1.518	.892	.19	.18	.417	13.37	14.15	+ .78	5.8
7771	1.770	1.636	.925	.14	.14	.400	12.56	13.28	+ .72	5.7
7772	1.379	1.050	.762	.46	.36	.400	12.56	12.40	-.16	1.3

TABLE XXV.—ORIGINAL SUBMERGED-FLOW DISCHARGE DATA FOR THE 3-FOOT PARSHALL MEASURING FLUME, 1923

Test	Flume heads		Ratio H_b/H_a	Loss of head		Head on weir	Discharge		Difference	Deviation
	H_a	H_b		Obs.	Comp.		Obs.	Comp.		
	Feet	Feet		Feet	Feet	Feet	Sec.-ft.	Sec.-ft.	Sec.-ft.	Percent
6408	2.358	1.697	0.720	-----	-----	1.252	45.66	44.13	-1.53	3.3
6411	2.039	1.509	.741	0.52	0.59	1.051	35.23	34.95	-.28	0.8
6412	2.179	1.773	.815	.40	.43	1.053	35.33	36.55	+1.22	3.5
6413	2.332	2.042	.875	.20	.32	1.042	34.78	37.10	+2.32	6.7
6417	1.653	1.227	.743	.43	.47	.838	25.12	25.24	+.12	0.5
6418	1.750	1.413	.807	.30	.35	.841	25.26	26.35	+1.09	4.3
6419	2.080	1.913	.920	.15	.16	.847	25.53	27.72	+2.19	8.6
6424	1.266	1.006	.794	.23	.28	.595	15.09	16.19	+1.10	7.3
6425	1.623	1.536	.946	.05	.09	.597	15.16	16.84	+1.68	11.1
6429	.733	.532	.726	.20	.22	.356	7.03	7.09	+.06	0.9
6430	.896	.836	.933	.08	.07	.353	6.95	7.10	+.15	2.2
6498	.800	.615	.769	.20	.21	V.M.*	8.09	8.00	-.09	1.1
6499	.807	.715	.886	.13	.11	V.M.	7.07	7.07	.00	0.0
6508	.900	.708	.787	.20	.20	V.M.	9.46	9.55	+.09	1.0
6509	1.040	.982	.945	.05	.06	V.M.	8.64	8.41	-.23	2.7
6510	.900	.874	.749	.23	.24	V.M.	9.69	9.74	+.05	0.5
6511	.900	.795	.884	.13	.12	V.M.	8.49	8.42	-.07	0.8
6514	.699	.499	.714	.21	.22	V.M.	6.74	6.61	-.13	1.9
6515	.710	.607	.855	.12	.11	V.M.	6.12	6.15	+.03	0.5
6516	.697	.622	.892	.09	.09	V.M.	5.58	5.52	-.06	1.1
6517	.712	.676	.949	.06	.04	V.M.	4.01	4.46	+.45	11.2
6520	.503	.379	.754	.12	.14	V.M.	3.93	3.85	-.08	2.0
6521	.500	.389	.778	.12	.12	V.M.	3.78	3.76	-.02	0.5
6522	.498	.442	.887	.07	.07	V.M.	3.43	3.25	-.18	5.2
6523	.499	.461	.924	.06	.05	V.M.	3.14	2.89	-.25	8.0
6528	.399	.297	.744	.11	.11	V.M.	2.75	2.66	-.09	3.3
6529	.399	.324	.812	.08	.08	V.M.	2.64	2.56	-.08	3.0
6530	.401	.353	.881	.06	.06	V.M.	2.43	2.34	-.09	3.7
6531	.399	.372	.932	.04	.04	V.M.	2.14	1.92	-.22	10.3
6534	.595	.446	.750	.15	.16	V.M.	5.13	5.06	-.07	1.4
6535	1.141	.914	.801	.27	.25	V.M.	13.97	13.70	-.27	1.9
6536	1.096	.957	.873	.16	.15	V.M.	11.53	11.73	+.15	1.3
6537	1.097	1.030	.939	.10	.07	V.M.	9.56	9.44	-.12	1.3
6538	1.199	1.065	.889	.16	.14	V.M.	13.06	12.99	-.07	0.5
6543	.996	.710	.713	.34	.32	V.M.	11.84	11.57	-.27	2.3
6544	1.004	.799	.796	.28	.24	V.M.	11.79	11.26	-.53	4.5
6545	.999	.865	.864	.17	.15	V.M.	10.30	10.30	.00	0.0
6547	1.000	.942	.942	.09	.07	V.M.	8.37	8.04	-.33	3.9
6550	.801	.757	.945	.07	.05	V.M.	5.67	5.55	-.12	2.1
6553	.900	.647	.720	.30	.28	V.M.	10.09	9.84	-.25	2.5

TABLE XXV.—(Continued)

Test	Flume heads		Ratio H_b/H_a	Loss of head		Head on weir	Discharge		Difference	Deviation
	H_a	H_b		Obs.	Comp.		Obs.	Comp.		
	Feet	Feet		Feet	Feet	Feet	Sec.-ft.	Sec.-ft.	Sec.-ft.	Percent
6556	0.600	0.466	0.776	0.15	0.15	V.M.	5.13	5.06	—0.07	1.4
6657	.597	.508	.851	.11	.10	V.M.	4.94	4.70	— .24	4.9
6558	.599	.569	.950	.06	.04	V.M.	3.75	3.34	— .41	10.9
6560	.981	.757	.772	.29	.25	V.M.	11.34	11.05	— .29	2.5
6561	.999	.769	.770	.30	.26	V.M.	11.92	11.36	— .56	4.7
6562	1.002	.952	.950	.08	.06	V.M.	7.88	7.68	— .20	2.5
6563	1.000	.754	.754	.31	.23	V.M.	11.81	11.47	— .34	2.9
6565	1.196	1.024	.856	.19	.13	V.M.	13.66	13.32	+ .34	1.2
6566	1.387	1.304	.940	.12	.08	V.M.	13.07	13.63	+ .56	4.3
6569	1.596	1.484	.930	.15	.12	V.M.	17.73	17.73	.00	0.0
6570	1.400	1.215	.867	.21	.21	V.M.	16.93	17.27	+ .34	2.0
6571	1.413	1.322	.932	.12	.10	V.M.	14.42	14.63	+ .21	1.5
6575	.298	.221	.742	.09	.08	V.M.	1.71	1.64	— .07	4.1
6576	.299	.255	.853	.06	.05	V.M.	1.59	1.51	— .08	5.0
6577	.300	.281	.937	.03	.02	V.M.	1.21	1.12	— .09	7.4
7123	2.520	2.200	.873	.30	.33	1.097	37.58	41.89	+4.31	11.5
7124	2.197	1.958	.892	.18	.23	.924	29.04	32.64	+3.60	12.4
7131	1.211	1.103	.911	.12	.11	.492	11.39	12.40	+1.01	8.9
7132	1.063	.852	.798500	11.67	12.39	+ .72	6.2
7133	1.477	1.216	.824	.23	.27	.690	18.78	19.94	+1.16	6.2
7136	2.456	2.292	.934	.16	.15	.932	29.42	34.00	+4.58	15.6

*Volumetric measurements, Hydraulic Laboratory, Fort Collins.

TABLE XXVI.—ORIGINAL SUBMERGED-FLOW DISCHARGE DATA FOR THE 4-FOOT PARSHALL MEASURING FLUME, 1923

Test	Flume heads		Ratio H_b/H_a	Loss of head		Head on weir	Discharge		Difference	Deviation
	H_a	H_b		Obs.	Comp.		Obs.	Comp.		
	Feet	Feet		Feet	Feet	Feet	Sec.-ft.	Sec.-ft.	Sec.-ft.	Percent
6373	1.702	1.293	0.760	0.39	0.46	1.055	35.44	35.17	-0.27	0.8
6374	1.804	1.519	.842	.22	.31	1.050	35.18	35.79	+ .61	1.7
6375	2.088	1.955	.937	.12	.14	1.022	33.78	35.72	+1.94	5.7
6382	2.008	1.475	.735	.49	.58	1.264	46.31	46.09	- .22	0.5
6383	2.082	1.688	.810	.30	.44	1.252	45.66	46.32	+ .66	1.4
6384	2.280	2.064	.905	.16	.23	1.210	43.42	45.53	+2.11	4.9
6393	1.624	1.508	.929	.11	.13	.822	24.42	24.91	+ .49	2.0
6394	1.421	1.177	.828	.26	.27	.825	24.55	25.15	+ .60	2.4
6395	1.339	.977	.730	.33	.40	.825	24.55	24.49	- .06	0.2
6399	1.014	.791	.780	.19	.24	.595	15.09	15.42	+ .33	2.2
6400	1.248	1.180	.946	.09	.08	.603	15.38	15.13	- .25	1.6
7096	2.372	1.687	.711	1.522	60.98	60.32	- .66	1.1
7100	1.998	1.614	.808	.45	.44	1.227	44.32	43.55	- .77	1.7
7101	2.303	2.096	.910	.25	.23	1.221	44.00	45.64	+1.64	3.7
7102	2.059	1.931	.938	.20	.14	1.025	33.93	34.79	+ .86	2.5
7109	1.807	1.683	.931	.16	.13	.888	27.37	29.20	+1.83	6.7
7110	1.429	1.099	.769	.39	.36	.881	27.06	26.64	- .42	1.6
7111	1.783	1.517	.851	.29	.29	1.025	33.93	34.73	+ .80	2.4
7112	1.174	1.097	.934	.10	.08	.573	14.28	14.61	+ .33	2.3
7115	1.064	.943	.886	.13	.12	.577	14.42	14.63	+ .21	1.5
Check Tests, Bellvue Laboratory, 1926										
7457	0.734	0.536	0.730	0.21	0.22	0.336	9.68	9.45	-0.23	2.4
7458	.753	.604	.802	.17	.17	.332	9.51	9.52	+ .01	0.1
7459	.811	.728	.898	.10	.09	.335	9.64	9.26	- .38	3.9
7460	.870	.811	.932	.08	.07	.334	9.59	9.15	- .44	4.6
7462	.545	.390	.715	.16	.17	.242	5.96	5.89	- .07	1.2
7463	.587	.428	.729	.17	.17	.261	6.66	6.59	- .07	1.0
7464	.600	.486	.810	.14	.12	.260	6.62	6.56	- .06	0.9
7465	.626	.558	.891	.09	.08	.256	6.47	6.24	- .23	3.6
7466	.644	.590	.916	.09	.06	.254	6.40	6.07	- .33	5.2
7468	.270	.214	.792	.07111	1.94	1.75	- .19	9.8
7469	.312	.292	.936	.02110	1.92	1.62	- .30	15.6
7470	.272	.224	.824	.06111	1.94	1.74	- .20	10.3
7472	1.779	1.276	.717	.60	.58	.854	38.98	38.40	- .58	1.5
7473	1.794	1.487	.829	.37	.34	.821	36.76	36.06	- .70	1.9
7474	1.856	1.655	.892	.25	.22	.784	34.31	34.24	- .07	0.2

TABLE XXVI.—Check Tests (Continued)

Test	Flume heads		Ratio H _b /H _a	Loss of head		Head on weir	Discharge		Difference	Deviation
	H _a	H _b		Obs.	Comp.		Obs.	Comp.		
	Feet	Feet		Feet	Feet	Feet	Sec.-ft.	Sec.-ft.	Sec.-ft.	Percent
7475	1.928	1.782	.924	.20	.16	.750	32.11	33.15	+1.04	3.2
7477	1.582	1.175	.743	.47	.47	.747	31.92	31.65	— .27	0.8
7478	1.675	1.440	.860	.28	.26	.736	31.22	31.09	— .13	0.4
7479	1.750	1.578	.902	.22	.19	.722	30.34	30.48	+ .14	0.5
7480	1.859	1.748	.941	.16	.12	.696	28.73	29.26	+ .53	1.8
7481	1.861	1.751	.942	.17	.12	.696	28.73	29.22	+ .49	1.7
7484	1.352	.984	.728	.42	.42	.639	25.29	24.91	— .38	1.5
7485	1.414	1.153	.816	.28	.28	.627	24.59	25.25	+ .66	2.7
7486	1.526	1.376	.902	.18	.17	.629	24.70	24.66	— .04	0.2
7489	1.875	1.393	.744	.57	.55	.902	42.30	41.22	—1.08	2.6
7490	1.920	1.597	.832	.43	.37	.884	41.05	39.92	—1.13	2.8
7491	2.013	1.801	.895	.30	.23	.843	38.23	38.55	+ .32	0.8
7492	2.114	1.984	.933	.17	.14	.805	35.69	36.30	+ .61	1.7
7494	1.981	1.429	.721	.68	.62	.962	46.57	45.39	—1.18	2.5
7495	2.031	1.629	.802	.51	.45	.957	46.21	44.91	—1.30	2.8
7496	2.142	1.889	.882	.36	.27	.926	44.00	43.65	— .35	0.8
7497	2.243	2.070	.922	.23	.20	.893	41.67	42.24	+ .57	1.4
7501	2.517	1.857	.738	1.239	67.94	65.37	—2.57	3.8
7502	2.305	1.803	.782	.64	.56	1.097	56.67	55.51	—1.16	2.0
7503	2.546	2.318	.911	.32	.25	1.056	53.54	53.20	— .34	0.6
7507	1.127	.865	.767	.27	.29	.516	18.39	18.38	— .01	0.1
7508	1.143	.922	.806	.27	.25	.515	18.34	18.29	— .05	0.3
7509	1.194	1.045	.875	.20	.17	.508	17.96	17.91	— .05	0.3
7510	1.286	1.213	.943	.11	.09	.474	16.19	16.20	+ .01	0.1
7511	1.051	.743	.707	.37	.34	.492	17.12	16.85	— .27	1.6
7513	1.081	.830	.767	.25	.27	.490	17.02	17.23	+ .21	1.2
7514	1.604	1.164	.726	.51	.50	.764	33.01	32.57	— .44	1.3
7515	1.613	1.185	.735	.53	.48	.771	33.47	32.75	— .72	2.1
7516	1.635	1.245	.761	.38	.43	.773	33.60	33.02	— .58	1.7

TABLE XXVII.—ORIGINAL SUBMERGED-FLOW DISCHARGE DATA FOR THE 6-FOOT PARSHALL MEASURING FLUME, 1923

Test	Flume heads		Ratio H_b/H_a	Loss of head		Head on weir	Discharge		Difference	Deviation
	H_a	H_b		Obs.	Comp.		Obs.	Comp.		
	Feet	Feet		Feet	Feet	Feet	Sec.-ft.	Sec.-ft.	Sec.-ft.	Percent
6339	1.562	1.120	0.717	0.49	0.51	1.322	49.51	47.50	-2.01	4.1
6340	1.617	1.273	.787	.31	.40	1.332	50.07	48.56	-1.51	3.0
6341	1.774	1.564	.882	.16	.24	1.348	50.97	50.29	-.68	1.3
6347	1.396	1.065	.763	.34	.38	1.148	40.20	39.01	-1.19	3.0
6348	1.492	1.303	.873	.19	.21	1.146	40.09	38.95	-1.14	2.8
6353	1.143	.803	.702	.39	.39	.945	30.04	29.02	-1.02	3.4
6354	1.171	.905	.773	.20	.30	.943	29.94	29.36	-.58	1.9
6355	1.357	1.270	.936	.10	.10	.945	30.04	28.40	-1.64	5.5
6359	.900	.678	.753	.24	.25	.722	20.11	19.52	-.59	2.9
6360	.941	.784	.833	.16	.18	.723	20.16	19.85	-.31	1.5
6361	1.037	.961	.927	.08	.09	.726	20.28	19.11	-1.17	5.8
6366	.590	.487	.825	.11	.12	.445	9.79	9.47	-.32	3.3
7080	2.111	1.936	.917	.25	.20	1.499	59.61	61.06	+1.45	2.4
7085	1.669	1.457	.873	.27	.23	1.248	45.44	46.46	+1.02	2.2
7089	1.227	1.092	.890	.19	.15	.906	28.20	27.71	-.49	1.7
7093	1.384	1.316	.950	.13	.08	.897	27.78	27.53	-.25	0.9
Check Tests, Bellvue Laboratory, 1926										
7390	0.330	0.232	0.703	0.13	0.10	0.186	4.04	3.80	-0.24	5.9
7391	.378	.357	.944	.03	.03	.178	3.79	3.28	-.51	13.4
7392	.342	.292	.854	.08	.06	.186	4.04	3.74	-.30	7.4
7395	.646	.498	.771	.20	.16	.376	11.45	11.36	-.09	0.8
7396	.666	.560	.841	.15	.11	.374	11.36	11.36	.00	0.0
7397	.690	.611	.886	.16	.10	.372	11.27	11.17	-.10	0.9
7398	.704	.636	.903	.13	.07	.371	11.23	11.09	-.14	1.2
7401	.784	.655	.836	.18	.14	.447	14.83	14.77	-.06	0.4
7402	.862	.794	.921	.11	.07	.442	14.59	14.55	-.04	0.3
7404	.772	.550	.713	.26	.24	.458	15.38	15.46	+ .08	0.5
7405	.788	.642	.815	.21	.16	.456	15.28	15.21	-.07	0.5
7406	.830	.737	.888	.15	.10	.454	15.18	14.95	-.23	1.5
7407	.893	.834	.934	.12	.06	.451	15.03	14.62	-.41	2.7
7409	.921	.666	.723	.26	.28	.550	20.22	20.45	+ .23	1.1
7410	.940	.755	.804	.26	.20	.552	20.33	20.33	.00	0.0
7411	1.004	.900	.896	.15	.11	.545	19.95	19.89	-.06	0.3
7412	1.083	1.017	.939	.14	.07	.538	19.57	19.56	-.01	0.1
7413	1.216	1.134	.932	.15	.09	.614	23.83	24.13	+ .35	1.5
7414	1.151	1.036	.900	.18	.13	.622	24.30	24.49	+ .19	0.8
7415	1.078	.890	.825	.23	.20	.630	24.76	24.81	+ .05	0.2

TABLE XXVII.—Check Tests (Continued)

Test	Flume heads		Ratio H _b /H _a	Loss of head		Head on weir	Discharge		Difference	Deviation
	H _a	H _b		Obs.	Comp.		Obs.	Comp.		
	Feet	Feet		Feet	Feet	Feet	Sec.-ft.	Sec.-ft.	Sec.-ft.	Percent
7416	1.046	.762	.728	.29	.31	.634	25.00	24.97	— .03	0.1
7419	1.166	.832	.713	.39	.37	.719	30.15	29.89	— .26	0.9
7420	1.194	.939	.786	.29	.29	.717	30.02	30.09	+ .07	0.2
7421	1.302	1.184	.910	.20	.13	.706	29.34	29.04	— .30	1.0
7422	1.390	1.308	.941	.15	.09	.689	28.30	28.90	+ .60	2.1
7423	2.296	1.612	.702	1.480	88.46	87.82	— .64	0.7
7424	2.315	1.709	.738	.84	.65	1.468	87.40	87.72	+ .32	0.4
7425	2.464	2.196	.887	.45	.29	1.439	84.85	83.36	— 1.49	1.8
7427	2.348	1.878	.800	.68	.50	1.463	86.96	86.34	— .62	0.7
7429	2.245	1.574	.701	1.443	85.20	84.82	— .38	0.4
7430	2.304	1.867	.810	.59	.47	1.429	83.98	83.16	— .82	1.0
7432	2.483	2.258	.908	.37	.24	1.387	80.35	80.70	+ .35	0.4
7435	2.141	1.705	.796	.57	.47	1.328	75.33	74.96	— .37	0.5
7436	2.280	2.049	.898	.35	.26	1.302	73.15	72.15	— 1.00	1.4
7437	2.446	2.315	.946	.24	.15	1.222	66.55	70.00	+ 3.45	5.2
7439	1.972	1.379	.700	.77	.65	1.254	69.17	69.04	— .13	0.2
7440	2.004	1.600	.798	.58	.44	1.254	69.17	67.53	— 1.64	2.4
7441	2.146	1.941	.905	.36	.23	1.206	65.26	64.58	— .68	1.0
7442	2.304	2.171	.942	.22	.15	1.168	62.22	64.63	+ 2.41	3.9
7444	1.827	1.285	.703	.70	.61	1.166	62.06	61.17	— .89	1.4
7445	1.866	1.496	.801	.49	.42	1.150	60.80	60.22	— .58	1.0
7447	1.590	1.132	.712	.56	.54	1.006	49.79	48.95	— .84	1.7
7448	1.615	1.285	.796	1.004	49.65	48.11	— 1.54	3.1
7449	1.713	1.528	.889	.29	.21	.981	47.95	47.22	— .73	1.5
7450	1.850	1.737	.940	.20	.13	.942	45.13	45.91	+ .78	1.7
7452	1.391	.995	.715	.49	.44	.870	40.08	39.51	— .57	1.4
7453	1.441	1.179	.818	.34	.30	.868	39.94	39.55	— .39	1.0
7454	1.527	1.365	.894	.25	.18	.857	39.19	38.81	— .38	1.0
7455	1.598	1.483	.928	.20	.13	.847	38.51	38.01	— .50	1.3

TABLE XXVIII.—ORIGINAL SUBMERGED-FLOW DISCHARGE DATA FOR THE 8-FOOT PARSHALL MEASURING FLUME, 1923

Test	Flume heads		Ratio H _b /H _a	Loss of head		Head on weir	Discharge		Difference	Deviation
	H _a	H _b		Obs.	Comp.		Obs.	Comp.		
	Feet	Feet		Feet	Feet	Feet	Sec.-ft.	Sec.-ft.	Sec.-ft.	
6296	1.522	1.305	0.857	0.20	0.24	1.421	55.10	55.73	+0.63	1.1
6297	1.554	1.351	.870	.15	.21	1.432	55.72	56.51	+ .79	1.4
6298	1.608	1.464	.910	.12	.16	1.429	55.55	55.25	— .30	0.5
6299	1.686	1.576	.935	.08	.12	1.423	55.12	55.45	+ .33	0.6
6305	1.270	.937	.738	.25	.37	1.244	45.23	45.46	+ .23	0.5
6306	1.320	1.125	.852	.14	.20	1.244	45.23	44.70	— .53	1.2
6307	1.480	1.383	.935	.08	.11	1.265	46.37	44.91	—1.46	3.2
6313	1.064	.774	.727	.25	.33	1.048	35.08	34.39	— .69	2.0
6314	1.124	.954	.849	.17	.18	1.055	35.44	34.78	— .66	1.9
6315	1.225	1.142	.932	.08	.10	1.050	35.18	33.44	—1.74	4.9
6322	.939	.839	.894	.10	.10	.840	25.21	24.22	— .99	3.9
6327	.690	.630	.913	.07	.07	.592	14.97	14.06	— .91	6.1
6334	.403	.291	.722349	6.83	7.00	+ .17	2.5
7015	2.100	1.952	.930	.13	.16	1.765	76.04	80.16	+4.12	5.4
7016	2.099	1.948	.929	.14	.16	1.763	75.91	80.29	+4.38	5.8
7017	2.415	2.276	.942	.12	.16	1.987	90.64	96.47	+5.83	6.4
7018	2.427	2.294	.945	.13	.15	2.000	91.52	96.26	+4.74	5.2
7019	2.199	2.076	.945	1.829	80.16	82.04	+1.88	2.3
7021	1.903	1.773	.932	.13	.15	1.620	66.93	68.01	+1.08	1.6
7022	2.006	1.868	.931	.14	.15	1.692	71.42	74.24	+2.82	4.0
7023	1.755	1.629	.928	.13	.14	1.516	60.62	60.50	— .12	0.2
7024	1.441	1.312	.910	.13	.14	1.284	47.41	46.38	—1.03	2.2
7025	1.365	1.237	.906	.15	.15	1.225	44.22	42.94	—1.28	2.9
7026	1.693	1.566	.925	.15	.15	1.473	58.09	57.57	— .52	0.9
7034	1.576	1.436	.911	.14	.16	1.390	53.33	53.35	+ .02	0.0
7035	2.026	1.878	.927	.14	.17	1.702	72.05	76.30	+4.25	5.9
7039	1.127	.992	.880	.14	.15	1.039	34.63	33.38	—1.25	3.6
7046	1.097	.883	.805	.18	.23	1.046	34.98	34.82	— .16	0.5
7054	.883	.737	.835	.14	.15	.829	24.73	23.99	— .74	3.0
7057	1.958	1.497	.765	.44	.49	1.972	89.62	89.73	+ .11	0.1
7068	1.903	1.430	.751	.45	.50	1.924	86.39	86.32	— .07	0.1
7059	1.766	1.249	.707	.50	.55	1.792	77.77	77.81	+ .04	0.1
7062	1.941	1.540	.793	.36	.42	1.940	87.46	87.01	— .45	0.5
7063	1.753	1.302	.743	.44	.48	1.775	76.68	75.96	— .72	0.9
7065	1.873	1.454	.776	.39	.45	1.877	83.28	83.14	— .14	0.2

Check Tests, Bellvue Laboratory, 1926
 Mean Width of Throat, 7.98 Feet; Tests 7285 to 7388, inclusive

7287	1.538	1.236	.804	.38	.35	1.185	63.58	59.70	—3.88	6.1
7288	1.544	1.255	.813	.37	.33	1.185	63.58	59.61	—3.97	6.2

TABLE XXVIII.—Check Tests (Continued)

Test	Flume heads		Ratio H _b /H _a	Loss of head		Head on weir	Discharge		Difference	Deviation
	H _a	H _b		Obs.	Comp.		Obs.	Comp.		
	Feet	Feet		Feet	Feet	Feet	Sec.-ft.	Sec.-ft.	Sec.-ft.	Percent
7289	1.664	1.531	.920	.22	.16	1.135	59.62	56.83	—2.79	4.7
7296	1.493	1.235	.827	.31	.30	1.114	57.98	55.85	—2.13	3.7
7299	1.444	1.047	.726	.52	.44	1.109	57.59	56.09	—1.50	2.6
7304	.458	.353	.771	.12	.12	.324	9.17	8.54	— .63	6.9
7305	.544	.515	.946	.06	.03	.320	9.00	8.20	— .80	8.9
7308	.772	.623	.807	.30	.17	.556	20.55	19.75	— .80	3.9
7309	.841	.774	.920	.11	.08	.557	20.61	18.94	—1.67	8.1
7313	1.000	.707	.707	.38	.34	.751	32.17	31.16	—1.01	3.1
7314	1.029	.833	.810	.28	.22	.744	31.73	31.22	— .51	1.6
7315	1.088	.965	.886	.19	.14	.744	31.73	31.12	— .61	1.9
7316	1.212	1.145	.945	.13	.08	.729	30.78	31.09	+ .31	1.0
7318	1.166	.900	.772	.34	.30	.863	39.60	39.02	— .58	1.5
7319	1.198	.992	.827	.25	.22	.862	39.53	39.22	— .31	0.8
7320	1.269	1.138	.897	.11	.14	.862	39.53	38.87	— .66	1.7
7321	1.387	1.306	.942	.14	.09	.852	38.85	39.30	+ .45	1.2
7323	1.425	1.016	.713	.50	.45	1.093	56.36	55.00	—1.36	2.4
7324	1.471	1.199	.815	.34	.30	1.083	55.59	54.98	— .61	1.1
7325	1.580	1.430	.905	.24	.17	1.073	54.83	54.24	— .59	1.1
7326	1.726	1.640	.949	.16	.10	1.047	52.86	54.38	+1.52	2.9
7329	1.522	1.080	.710	.56	.50	1.179	63.10	61.13	—1.97	3.1
7330	1.529	1.120	.733	.50	.45	1.174	62.70	61.22	—1.48	2.4
7331	1.548	1.192	.770	.44	.39	1.175	62.78	61.41	—1.37	2.2
7332	1.565	1.255	.802	.42	.35	1.171	62.46	61.30	—1.16	1.9
7333	1.669	1.502	.900	.25	.19	1.148	60.64	59.83	— .81	1.3
7334	1.726	1.595	.924	.23	.15	1.134	59.54	59.29	— .25	0.4
7335	1.554	1.329	.855	.30	.25	1.130	59.23	57.55	—1.68	2.8
7336	1.553	1.323	.852	.29	.25	1.131	59.31	57.70	—1.61	2.7
7337	1.482	1.055	.712	.53	.48	1.142	60.17	58.61	—1.56	2.6
7339	1.624	1.356	.835	.34	.30	1.210	65.58	63.17	—2.41	3.7
7341	1.640	1.384	.844	.34	.28	1.211	65.66	63.46	—2.20	3.3
7342	1.783	1.664	.934	.19	.14	1.184	63.50	60.70	—2.80	4.4
7343	1.734	1.573	.908	.24	.17	1.180	63.18	62.45	— .73	1.2
7344	1.670	1.445	.866	.26	.25	1.217	66.15	63.57	—2.58	3.9
7345	1.634	1.336	.818	.37	.33	1.219	66.31	64.84	—1.47	2.2
7348	.359	.310	.864	.07	.05	.239	5.85	5.24	— .61	10.4
7349	.390	.361	.926	.04	.03	.236	5.75	5.14	— .61	10.6
7352	.653	.544	.833	.15	.12	.459	15.43	14.74	— .69	4.5
7354	.728	.680	.934	.09	.05	.453	15.13	14.15	— .98	6.5
7356	1.501	1.306	.870	.25	.22	1.074	54.90	53.40	—1.50	2.7
7357	1.427	1.075	.754	.41	.38	1.080	55.36	54.37	— .99	1.8

TABLE XXVIII.—Check Tests (Concluded)

Test	Flume heads		Ratio H _b /H _a	Loss of head		Head on weir	Discharge		Difference	Deviation
	H _a	H _b		Obs.	Comp.		Obs.	Comp.		
	Feet	Feet		Feet	Feet	Feet	Sec.-ft.	Sec.-ft.	Sec.-ft.	
7360	1.829	1.294	.708	.64	.60	1.434	84.42	82.13	-2.29	2.7
7361	1.874	1.510	.806	1.419	83.11	81.34	-1.77	2.1
7362	2.038	1.830	.898	.25	.22	1.379	79.66	82.45	+2.79	3.5
7363	2.130	1.974	.927	.22	.17	1.362	78.21	82.50	+4.29	5.5
7365	1.700	1.215	.715	.57	.52	1.313	74.07	72.90	-1.17	1.6
7366	1.754	1.422	.811	1.296	72.65	72.99	+ .34	0.5
7367	1.886	1.686	.894	.19	.21	1.295	72.57	73.51	+ .94	1.3
7368	2.089	1.972	.944	.17	.13	1.281	71.40	75.62	+4.22	5.9
7370	.745	.549	.737537	19.52	19.18	- .34	1.7
7371	.760	.630	.829	.15	.14	.536	19.46	18.85	- .61	3.1
7372	.844	.786	.931	.10	.06	.530	19.14	18.26	- .88	4.6
7373	.864	.813	.941	.06	.06	.526	18.92	18.18	- .74	3.9
7374	.916	.856	.934	.11	.07	.569	21.27	20.67	- .60	2.8
7375	.880	.795	.903	.11	.10	.574	21.54	21.31	- .23	1.1
7376	.803	.616	.767	.21	.21	.580	21.88	21.48	- .40	1.8
7377	.796	.559	.702	.27	.27	.581	21.94	21.54	- .40	1.8
7520	1.510	1.112	.736	.47	.44	1.145	60.41	60.06	- .35	0.6
Mean Width of Throat, 8.00 Feet; Tests 7518 to 7554, inclusive										
7521	1.664	1.502	.903	.21	.19	1.133	59.46	59.31	- .15	0.3
7522	1.712	1.588	.927	.18	.14	1.105	57.29	58.27	+ .98	1.7
7525	1.370	1.021	.746	.43	.39	1.028	51.43	51.19	- .24	0.5
7526	1.453	1.263	.869	.26	.23	1.022	50.98	50.88	- .10	0.2
7527	1.557	1.441	.925	.18	.14	1.010	50.09	50.33	+ .24	0.5
7530	1.155	.941	.791	.29	.27	.843	38.23	38.13	- .10	0.3
7531	1.188	1.013	.853	.21	.20	.841	38.10	37.73	- .37	1.0
7532	1.267	1.162	.917	.17	.12	.829	37.29	37.02	- .27	0.7
7533	1.324	1.245	.940	.12	.09	.821	36.76	36.78	+ .02	0.1
7536	.998	.758	.760	.31	.26	.728	30.71	30.66	- .05	0.2
7537	1.019	.837	.822	.24	.20	.726	30.59	30.51	- .08	0.3
7538	1.086	.985	.907	.16	.11	.718	30.09	29.68	- .41	1.4
7539	1.136	1.061	.934	.11	.08	.712	29.71	29.40	- .31	1.1
7542	.965	.893	.925	.13	.08	.617	24.01	23.25	- .76	3.2
7543	.916	.828	.904	.13	.10	.602	23.14	22.77	- .37	1.6
7544	.859	.706	.822	.22	.17	.605	23.31	23.17	- .14	0.6
7546	.620	.445	.718	.31	.19	.442	14.59	14.30	- .29	2.0
7547	.628	.504	.803	.17	.14	.439	14.44	14.18	- .26	1.8
7548	.687	.628	.914	.09	.06	.436	14.29	13.89	- .40	2.8
7549	.734	.695	.947	.08	.04	.431	14.05	13.52	- .53	3.8
7551	.406	.349	.860	.08	.06	.272	7.08	6.55	- .53	7.5
7552	.420	.378	.900	.08	.05	.272	7.08	6.37	- .71	10.0

TABLE XXIX.—SPECIAL TESTS ON 8-FOOT PARSHALL MEASURING FLUME TO SHOW THE EFFECT ON DISCHARGE BY INCREASING THE LENGTH OF CONVERGING SECTION; MEASUREMENT OF HEADS IN FLUME AT THE STANDARD POINTS

Test	Flume heads		Ratio H_b/H_a	Head on weir	Discharge		Difference	Deviation
	H_a	H_b			Obs.	Comp.		
	Feet	Feet		Feet	Sec.-ft.	Sec.-ft.	Sec.-ft.	Percent
7379	0.618	0.446	14.78	14.72	—0.06	0.4
7380	.756556	20.55	20.35	— .20	1.0
7381	.963720	30.21	30.05	— .16	0.5
7382	1.147869	40.01	39.79	— .22	0.6
7383	1.314	1.005	49.72	49.50	— .22	0.4
7384	1.440	1.107	57.44	57.36	— .08	0.1
7385	1.161	0.825	0.711	.871	40.15	39.61	— .54	1.3
7386	1.194	.951	.796	.862	39.53	39.97	+ .44	1.1
7387	1.276	1.155	.904	.850	38.71	38.59	— .12	0.3
7388	1.350	1.263	.936	.839	37.96	38.46	+ .50	1.3